

## VSS / VSH Stepper Motor

For Applications up to Ultra-High-Vacuum

Motors for use in vacuum should not only withstand the vacuum (no bursting of air inclusions), they must not contaminate the vacuum either. By selecting suitable materials and optimised conditioning processes Phytron VSS/VSH stepper motors are ideally suited for use in a vacuum. Through many years of experience with special materials for use in space, we have put a focus on materials with minimal molecular outgassing and high heat resistance. This is the prerequisite for a high vacuum quality and genuine measurement results in scientific and medical applications.

For exact positioning in vacuum, stepper motors are therefore particularly suitable because they can precisely position even without

sensitive feedback providers. Therefore Phytron VSS/VSH stepper motors can be used in particularly challenging environmental conditions (radiation, cryo-temperatures and in a modified design even in space).

Since stepper motors do not generate jitter effects while holding a position, this technology is ideal for precisely aligning optical instruments, mirrors, antennas or samples e.g. in high-resolution microscopes, particle accelerators or molecular analysis devices.

The VSS/VSH series is completely manufactured in Germany. You have special requirements? We will gladly develop a customised design for your application.

### In Focus



- 2-phase stepper motors
- Holding torques from 3.4 mNm to 13 Nm
- Diameters from 19 to 125 mm
- Number of steps 200 (standard)
- Step accuracy 5% for 1.8°
- Operating voltage (power stage)  
Size 19 to 57: 70 V<sub>DC</sub>  
Size 80 to 126: 120 V<sub>DC</sub>
- Outgassing holes to avoid pockets of trapped gas

### Options

- VGPL precision planetary gear or Harmonic Drive gear
- Thermocouple type KTC/ Pt100 resistor sensor
- Resolver
- Double shaft

### Customised solutions

- Operating in an aggressive environment
- Clean room applications to clean room class ISO 5 (acc. to ISO 14644-1)
- Motors with spindle

### Highlights



#### Performance & lifetime

Phytron in-Vacuum motors are based on a technology that can also be found in the most challenging projects of our time. From a variety of satellites up to the Mars rover Curiosity: Phytron motors drive applications in distant worlds - highly accurate, reliable and durable. Driven within their specification range, high quality components and a proven design make sure: These motors don't let you down!



#### Cleanliness

Phytron motors for use in ultra high vacuum (UHV) contain only materials that also meet the requirements of the ECSS (European Space regulations). Thus, each material has a maximum TML (Total Mass Loss) value < 1% and a maximum CVCM (Volatile Mass Losses) value < 0.1%. You will receive your UHV motor, double-wrapped and vacuum sealed.

## Extreme

## Phytron VSS/VSH Stepper Motor

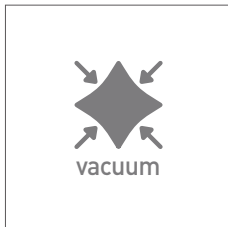
**Conditioning**

The combination of high quality materials and a special conditioning process allow minimal outgassing rates. So a vacuum of  $10^{-11}$  hPa can be achieved depending on the application. For this purpose, individual components of the UHV motors, such as the wound stator, are specially conditioned before installation, so that outgassing materials cannot be deposited in the ball bearings or inside the motor. The fully assembled motor is outgassed by a Phytron process at least 200 °C in vacuum chambers. Increased outgassing temperatures are available on request. The rule of thumb: the outgassing rate decreases with a decimal power for every 100 °C increase of the outgassing temperature. In the actual application the motor should always be driven at least 40 °C below the outgassing temperature.

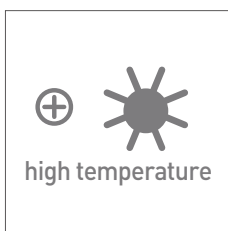
**Temperature management**

All materials selected for the UHV motors can withstand a short-term winding temperature of up to 300° C. Due to the lack of convection in vacuum, the motors can heat up very quickly and often work at a high temperature level - depending on the duty-cycle. In our UHV motors we integrate a thermocouple to allow monitoring of the exact winding temperature. All vacuum motors can be ordered as an alternative to the thermocouple also with platinum probes (PT) or customer- specific sensors. This is how you protect your motors safe from overheating.

**Adhesives**

The adhesives represent an optimum of strength, ductility, low outgassing rates and thermal resistance. The outgassing rates (TML, CVCM) comply with the European and US-American space standards. While the first adhesive is not brittle even at 4 K, the second adhesive retains sufficient strength even at a winding temperature of 300 °C for short periods without taking damage.

**Bearings**

The usage of un-lubricated ball bearings can cause so-called cold welding, and thus degrade and completely block the bearing. Therefore, it is advisable to use lubricated ball bearings whenever the application permits. For this purpose a special vacuum grease is necessary to provide not only low outgassing rates but also an extended life-time for the bearing. There is special lubrication for temperatures down to -50 °C or even -70 °C. However, the viscosity is so high that the efficiency decreases considerably. In low temperatures, the use of dry-lubricated bearings is recommended.

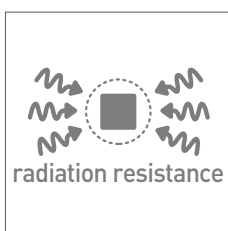
**Radiation resistance**

With ascending vacuum class motors are equally designed for higher radiation dose to be used in the vicinity of radiation sources (e.g. in medicine and research). While a fine vacuum motor can be safely used only up to a dose of 10 J/kg , a UHV motor may be safely operated up to a dose of  $10^6$  J/kg. A motor not designed for radiation will not only suffer degradation of the insulation and the adhesives - especially the grease of the ball bearing degrades, reduces the efficiency and ultimately blocks the motor.



### Structure design

As is commonly done in high vacuum class all structural elements such as housing, flanges and shafts are made of stainless steel. Outgassing holes in the rear flange also allow rapid evacuation and purging of the motors and make sure that no gas inclusions may occur. All structural elements of the magnetic circuit are basically protected against corrosion. This also allows temporarily handling in normal environment.



### Handling

Phytron VSS/VSH motors are primarily designed for use in vacuum. Although the components of the magnetic circuit are basically protected against corrosion, the motors should ideally be handled in clean rooms and clean boxes. A storage is permitted only in Phytron's original packaging. The motors are to be handled with suitable gloves. Since the rotor is magnetic, it must necessarily be handled in a clean environment so that no metal particles may be drawn into the motor. That could lead to an impairment of operation, reduce the life time or even cause the failure of the motor by blocking.



### Service, consulting and customising

Of course we are happy if you are satisfied by our standard! But even if our vacuum motor series contains the application experience of several decades - sometimes the standard is just not enough. We like to fit our motor for your application, because sometimes even small changes make all the difference. Special applications require special support: Our service experts are available even after the purchase.

## Vacuum Classes

|                                      | Winding temperature [°C] | Vacuum class [hPa] | Temperature sensor   | Radiation-resistant up to [J/kg] | Conditioning of the components | First outgassing at Phytron | TML [%] | CVCM [%] |
|--------------------------------------|--------------------------|--------------------|----------------------|----------------------------------|--------------------------------|-----------------------------|---------|----------|
| HV                                   | -20...+200               | 10 <sup>-7</sup>   | option               | 10 <sup>2</sup>                  | -                              | option                      | -       | -        |
| UHVS<br>solid lubrication            | -20...+300 <sup>1)</sup> | 10 <sup>-11</sup>  | type K <sup>2)</sup> | 10 <sup>6</sup>                  | yes                            | yes                         | <1      | <0.1     |
| UHVG<br>grease lubrication           | -20...+300 <sup>1)</sup> | 10 <sup>-11</sup>  | type K <sup>2)</sup> | 10 <sup>6</sup>                  | yes                            | yes                         | <1      | <0.1     |
| UHVC1<br>Cryo 1<br>solid lubrication | -200...+40               | 10 <sup>-11</sup>  | option               | 10 <sup>6</sup>                  | yes                            | -                           | <1      | <0.1     |
| UHVC2<br>Cryo 2<br>solid lubrication | -270...+40               | 10 <sup>-11</sup>  | option               | 10 <sup>6</sup>                  | yes                            | -                           | <1      | <0.1     |

<sup>1)</sup> short-term    <sup>2)</sup> Pt100 as an option

Extreme

Configuration Guide

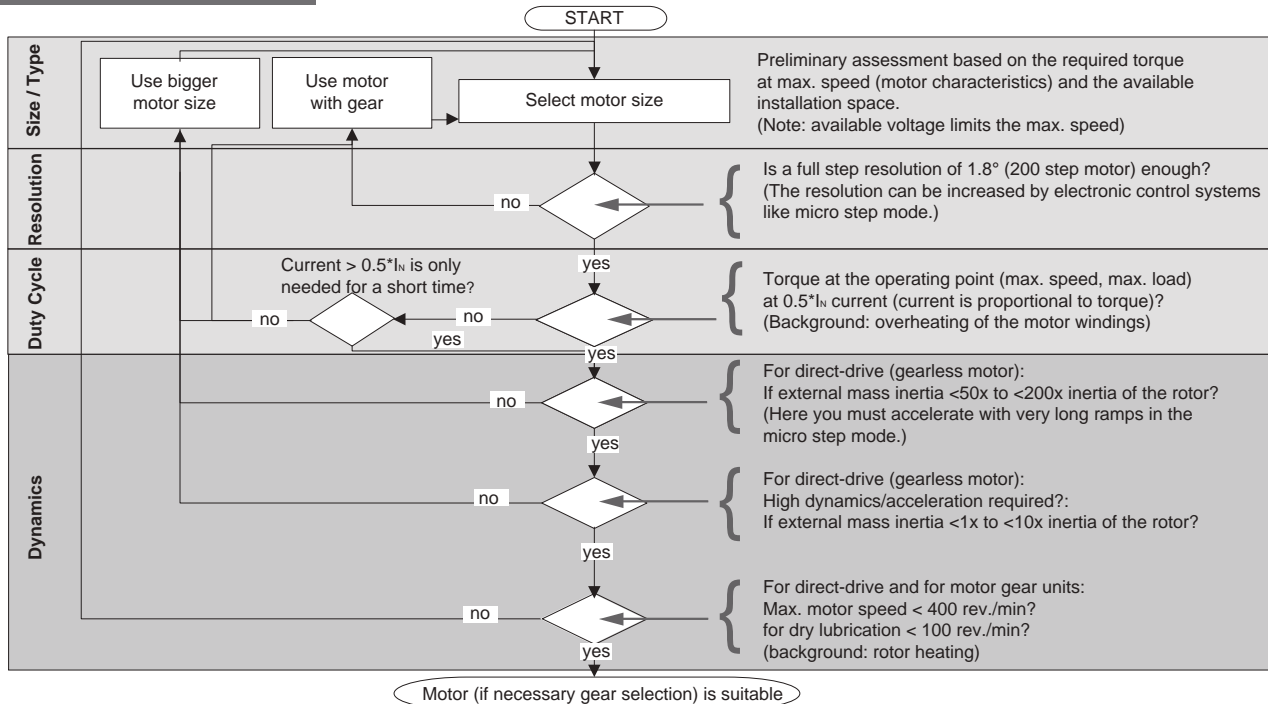

Derating - Duty-Cycle-Design for Applications in Vacuum

Motors driving in a vacuum heat up very quickly depending on their duty cycle. Driven with nominal current the maximum temperature will be reached within several minutes. Therefore it is necessary to monitor the motor's temperature (K-element) or to design a duty cycle with enough off-time to always keep the motor on a safe temperature level.

The shown curve is set at an environmental temperature of 20 °C. To give you an idea of how the chosen current influences the motor temperature we drew two curves of a VSS 57 motor. Driven with 400 rpm at 0.5 of the nominal current, the motor takes longer to heat up due to less ohmic losses then driven with the full nominal current.

The third curve (VSS 32) with 0.5 nominal current and 200 rpm only leads to a steady state temperature within the safe temperature limits. A higher rotational speed increases the magnetic losses. Therefore high speeds should be avoided as far as possible to reduce heat losses and to protect the bearings.

Winding temperature (in vacuum), environment 20 °C

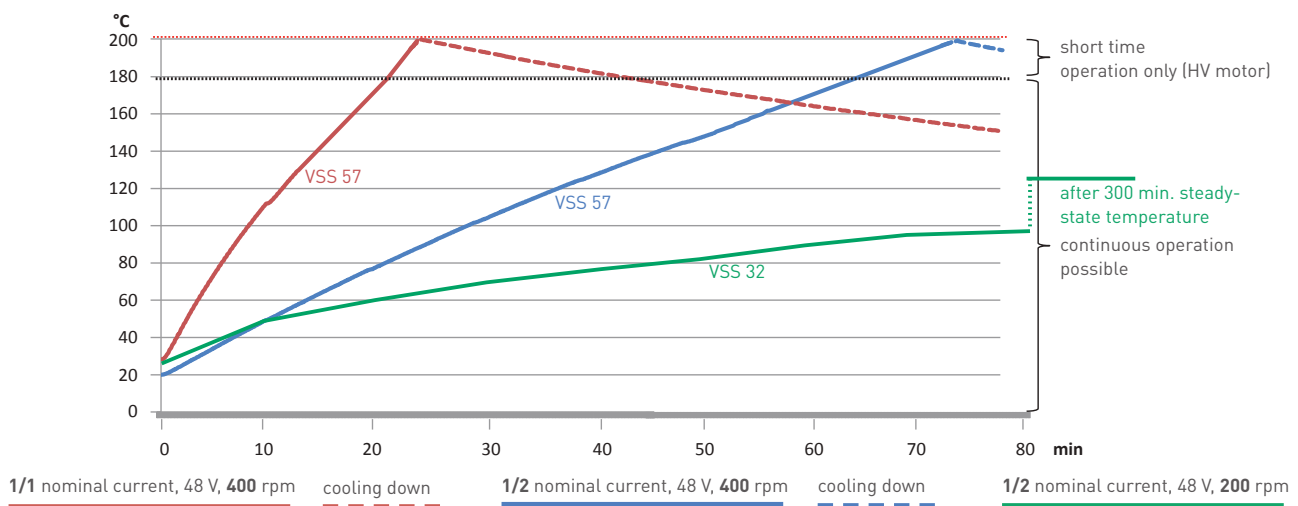

Stepper Motor VSS 19 to VSS 57, VSH 80 to VSH 126

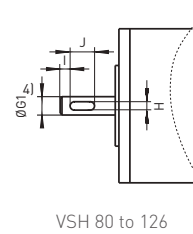
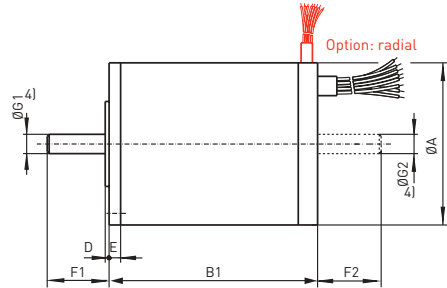
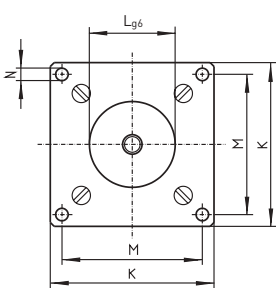

| Key     |   |     |    |
|---------|---|-----|----|
|         | H | I   | J  |
| VSH 80  | 3 | 2.5 | 20 |
| VSH 100 | 4 | 3   | 22 |
| VSH 126 | 5 | 3.5 | 22 |

Dimensions / Electrical and Mechanical Characteristics

| VSS/VSH<br>Standard<br>200-steps<br>4 lead<br>parallel <sup>3)</sup>               | Electrical characteristics                 |   |  |                           |          | Mechanical characteristics      |               |               |       |        |       |      | Dimensions in mm |     |     |      |      |                  |                  |     |      |      |      |
|--|--|---|--|---------------------------|----------|---------------------------------|---------------|---------------|-------|--------|-------|------|------------------|-----|-----|------|------|------------------|------------------|-----|------|------|------|
|  | Current/<br>phase IN                       | Resistance/<br>phase                        | Inductivity/<br>phase                        | max. operating<br>voltage | AWG      | Holding<br>torque <sup>2)</sup> | Detent torque | Rotor inertia | Loads |        | Mass  |      |                  |     |     |      |      |                  |                  |     |      |      |      |
|  |  |   |  |                           |          |                                 |               |               | axial | radial |       | A    | B1               | D   | E   | F1   | F2   | G1 <sup>4)</sup> | G2 <sup>4)</sup> | K   | L    | M    | N    |
| <a href="#">19.200.0.6<sup>1)</sup></a><br><a href="#">19.200.1.2<sup>1)</sup></a> | <a href="#">0.6</a><br><a href="#">1.2</a> | <a href="#">2.1</a><br><a href="#">0.63</a> | <a href="#">0.85</a><br><a href="#">0.23</a> |                           | 28       | 3.4<br>3.5                      | 0.9           | 0.0009        | 3     | 3      | 0.05  | 19   | 26.5             | 1   | 2   | 7.5  | 6.5  | 2.5              | 2.5              | 19  | 10   | 16   | M2.5 |
| 20.200.0.6<br>20.200.1.2   | 0.6<br>1.2                                 | 3.45<br>0.95                                | 1.1<br>0.4                                   |                           | 28       | 8                               | 1             | 0.002         | 3     | 3      | 0.075 | 19   | 43               | 1   | 2   | 7.5  | 6.5  | 2.5              | 2.5              | 19  | 10   | 16   | M2.5 |
| 25.200.0.6<br><a href="#">25.200.1.2<sup>1)</sup></a>                              | 0.6<br><a href="#">1.2</a>                 | 3.25<br><a href="#">0.95</a>                | 1.5<br><a href="#">0.4</a>                   |                           | 28<br>26 | 12                              | 2             | 0.0025        | 5     | 5      | 0.08  | 25   | 31               | 1   | 2.5 | 9.5  | 8.5  | 3                | 3                | 25  | 14   | 21.5 | 2.2  |
| 26.200.0.6<br>26.200.1.2   | 0.6<br>1.2                                 | 5.85<br>1.7                                 | 3.2<br>1.0                                   |                           | 28<br>26 | 28                              | 1.9           | 0.006         | 5     | 5      | 0.13  | 25   | 47               | 1   | 2.5 | 9.5  | 8.5  | 3                | 3                | 25  | 14   | 21.5 | 2.2  |
| 32.200.0.6<br><a href="#">32.200.1.2<sup>1)</sup></a>                              | 0.6<br><a href="#">1.2</a>                 | 4.6<br><a href="#">1.25</a>                 | 5.3<br><a href="#">1.2</a>                   |                           | 26       | 40                              | 3             | 0.01          | 5     | 15     | 0.17  | 32   | 38.5             | 1   | 3   | 11   | 10   | 4                | 4                | 32  | 18   | 27   | 2.8  |
| 33.200.0.6<br><a href="#">33.200.1.2<sup>1)</sup></a>                              | 0.6<br><a href="#">1.2</a>                 | 7.5<br><a href="#">1.9</a>                  | 9.3<br><a href="#">2.2</a>                   |                           | 26       | 68                              | 3.3           | 0.018         | 5     | 15     | 0.26  | 32   | 57.5             | 1   | 3   | 11   | 10   | 4                | 4                | 32  | 18   | 27   | 2.8  |
| <a href="#">42.200.1.2<sup>1)</sup></a><br><a href="#">42.200.2.5<sup>1)</sup></a> | <a href="#">1.2</a><br><a href="#">2.5</a> | <a href="#">1.7</a><br><a href="#">0.34</a> | <a href="#">3</a><br><a href="#">0.7</a>     |                           | 24<br>22 | 120                             | 5             | 0.045         | 20    | 40     | 0.35  | 42   | 54               | 1   | 3   | 16   | 15   | 5                | 4                | 42  | 22   | 36   | 3.2  |
| <a href="#">43.200.1.2<sup>1)</sup></a><br>43.200.2.5                              | <a href="#">1.2</a><br>2.5                 | <a href="#">2.6</a><br>0.5                  | <a href="#">5.2</a><br>1.2                   |                           | 24<br>22 | 235                             | 7             | 0.077         | 20    | 40     | 0.52  | 42   | 69               | 1   | 3   | 16   | 15   | 5                | 4                | 42  | 22   | 36   | 3.2  |
| 52.200.1.2<br>52.200.2.5   | 1.2<br>2.5                                 | 2.65<br>0.6                                 | 7<br>1.6                                     |                           | 24<br>22 | 350                             | 13            | 0.15          | 25    | 70     | 0.72  | 52   | 65               | 1.5 | 3.5 | 17.5 | 16   | 6                | 4                | 52  | 28   | 44   | 4.3  |
| 56.200.1.2<br>56.200.2.5   | 1.2<br>2.5                                 | 3.9<br>0.8                                  | 9.5<br>2.4                                   |                           | 24<br>22 | 420                             | 30            | 0.17          | 40    | 80     | 0.78  | 56.4 | 58.1             | 1.5 | 4.5 | 22   | 20.5 | 6.35             | 6.35             | 60  | 38.1 | 47.1 | 5.2  |
| 57.200.1.2<br><a href="#">57.200.2.5<sup>1)</sup></a>                              | 1.2<br><a href="#">2.5</a>                 | 3.9<br><a href="#">0.8</a>                  | 11.6<br><a href="#">2.9</a>                  |                           | 24<br>22 | 840                             | 50            | 0.24          | 40    | 80     | 0.99  | 56.4 | 74.1             | 1.5 | 4.5 | 22   | 20.5 | 6.35             | 6.35             | 60  | 38.1 | 47.1 | 5.2  |
| 80.200.5   | 5  | 0.4   | 2.3  |                           | 18       | 2300                            | 120           | 1.24          | 50    | 180    | 2.8   | 80   | 100              | 2   | 7.5 | 27   | 25   | 10               | 9                | 80  | 50   | 68   | 6.4  |
| 100.200.10   | 10   | 0.15  | 2.1  |                           | 16       | 4300                            | 140           | 4.4           | 70    | 300    | 5     | 100  | 125.5            | 2   | 8   | 32   | 30   | 12               | 12               | 100 | 60   | 86   | 6.4  |
| 126.200.10   | 10   | 0.23  | 3.9  |                           | 16       | 13000                           | 290           | 18.2          | 150   | 700    | 13.9  | 125  | 210              | 3   | 9.5 | 34   | 31   | 14               | 14               | 125 | 60   | 108  | 8.4  |

<sup>1)</sup> Preferred options: HV and UHVG in small quantities are available from stock

<sup>2)</sup> Holding torque in bipolar mode with parallel windings, two phases on at rated current

<sup>3)</sup> Other step resolutions on demand (with different mechanical characteristics!)

<sup>4)</sup> Shaft diameter tolerances: VSS 19 to 26: -0.005 to -0.009; from VSS 32: g5

All values given above refer to room temperature and atmospheric pressure.

Extreme

Stepper Motor with VGPL Gear

| Shaft |     |    |
|-------|-----|----|
| VGPL  | U1  | Z1 |
| 16    | 2.8 | 8  |
| 22    | 3.5 | 8  |
| 26    | 4.5 | 12 |

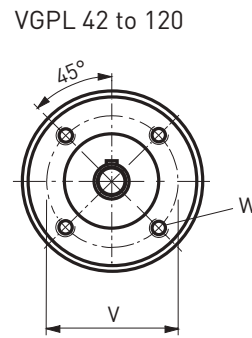
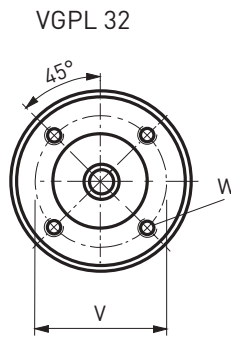
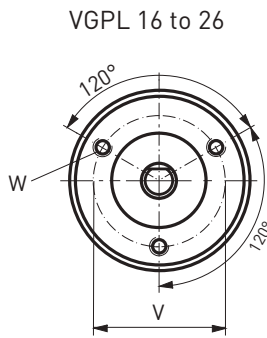
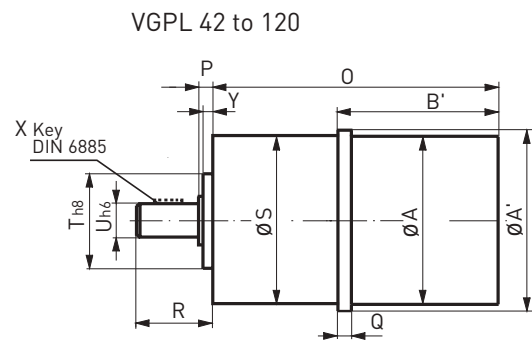
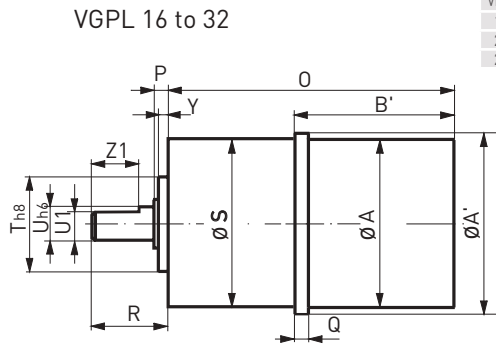

Dimensions

| Gear     | Stepper motor<br>VSS/<br>VSH | Dimensions in mm |                   |                    |                          |                          |                          |     |                  |      |     |    |    |     |         |                        |     |                           | Mass                      |                            |   |
|----------|------------------------------|------------------|-------------------|--------------------|--------------------------|--------------------------|--------------------------|-----|------------------|------|-----|----|----|-----|---------|------------------------|-----|---------------------------|---------------------------|----------------------------|---|
|          |                              | Stages           |                   |                    |                          |                          |                          |     |                  |      |     |    |    |     |         |                        |     |                           | Stages                    |                            |   |
|          |                              |                  |                   |                    | 1                        | 2                        | 3                        |     |                  |      |     |    |    |     |         |                        |     |                           | 1                         | 2                          | 3 |
|          |                              | A                | A'                | B'                 | O                        | P                        | Q                        | R   | S                | T    | U   | V  | W  | X   | Y       | [Motor and gear] in kg |     |                           |                           |                            |   |
| VGPL 16  | 19<br>20                     | 19               | 22                | 29<br>46           | 48<br>64.5               | 53<br>69.5               | 58<br>74.5               | 2   | 4.5              | 12.5 | 16  | 10 | 3  | 13  | M 2x4   | -                      | 1.5 | 0.07<br>0.09              | 0.07<br>0.1               | 0.08<br>0.11               |   |
| VGPL 22  | 19 / 20<br>25 / 26           | 19<br>25         | 22<br>25.5        | 29 / 50<br>34 / 50 | 50 / 66.5<br>54.5 / 70.5 | 57 / 73.5<br>61.5 / 77.5 | 64 / 80.5<br>68.5 / 84.5 | 2.5 | 5.5<br>5         | 15   | 22  | 12 | 4  | 16  | M 2.5x4 | -                      | 2   | 0.5 / 0.12<br>0.13 / 0.18 | 0.13 / 0.15<br>0.15 / 0.2 | 0.15 / 0.17<br>0.18 / 0.23 |   |
| VGPL 26  | 25 / 26                      | 25               | 26                | 34 / 50            | 59 / 74.5                | 67 / 82.5                | 75 / 90.5                | 2.5 | 5                | 17   | 26  | 14 | 5  | 20  | M 3x4   | -                      | 2   | 0.15 / 0.2                | 0.17 / 0.22               | 0.19 / 0.24                |   |
| VGPL 32  | 32 / 33                      | 32               | 33                | 41 / 60            | 69.5 / 88.5              | 78.5 / 97.5              | 87.5 / 106.5             | 4   | 5                | 20   | 32  | 20 | 6  | 26  | M 3x5   | -                      | 3   | 0.31 / 0.4                | 0.35 / 0.44               | 0.42 / 0.51                |   |
| VGPL 42  | 42 / 43                      | 42               | 43                | 58 / 83            | 93 / 118                 | 105.5 / 130.5            | 118 / 143                | 4   | 7                | 22.5 | 42  | 25 | 8  | 32  | M 4x8   | 3x3x14                 | 3   | 0.63 / 0.8                | 0.7 / 0.87                | 0.78 / 0.95                |   |
| VGPL 52  | 52<br>56 / 57                | 52<br>56 / 57    | 53<br>57          | 69<br>62 / 78      | 109.5<br>103 / 119       | 124<br>117.5 / 133.5     | 138.5<br>132 / 148       | 4   | 6.7<br>7         | 24   | 52  | 32 | 12 | 40  | M 5x8   | 4x4x16                 | 3   | 1.2<br>1.48 / 1.69        | 1.3<br>1.6 / 1.81         | 1.45<br>1.7 / 1.91         |   |
| VGPL 80  | 80                           | 80               | 80                | 116                | 160                      | 178                      | 196                      | 5   | 23.1             | 35   | 80  | 50 | 14 | 65  | M 6x12  | 5x5x20                 | 2.5 | 3.3                       | 4.9                       | 5.55                       |   |
| VGPL 105 | 80<br>100<br>126             | 80<br>100<br>125 | 105<br>105<br>125 | 116<br>146<br>210  | 183<br>208<br>277        | 205<br>235<br>299        | 232<br>262<br>326        | 6   | 23.1<br>8<br>9.5 | 46   | 105 | 70 | 20 | 85  | M 8x20  | 6x6x28                 | 2.5 | 6.05<br>8.25<br>17.15     | 7.55<br>9.75<br>18.65     | 9.05<br>11.25<br>20.25     |   |
| VGPL 120 | 126                          | 125              | 125               | 210                | 283.5                    | 313.5                    | 343.5                    | 7.5 | 9.5              | 57.5 | 120 | 80 | 25 | 100 | M 10x25 | 8x7x40                 | 3   | 18.9                      | 21.15                     | 23.4                       |   |

Mechanical Characteristics

| Gear     | Stepper motor      | Gear back-lash <sup>1)5)6)7)</sup> |     |     | Rated torque <sup>4) 6)8)</sup> |     |      | Gear inertia       |       |              | Radial load <sup>2)</sup>              | Axial load   | Efficiency at full load <sup>3)</sup> |    |    | Reduction ratio i [:1] |  |   |              |   |  |
|----------|--------------------|------------------------------------|-----|-----|---------------------------------|-----|------|--------------------|-------|--------------|--|--|---------------------------------------|----|----|------------------------|--|---|--------------|---|--|
|          |                    | arc-min                            |     |     | Nm                              |     |      | kg cm <sup>2</sup> |       |              |  |  | %                                     |    |    | i [:1]                 |  |   |              |   |  |
|          | VSS/VSH            | Stage                              |     |     | Stage                           |     |      | Stage              |       |              |  |  | Stage                                 |    |    | Stage 1                | Stage 2  | Stage 3   |              |   |  |
|          |                    | 1                                  | 2   | 3   | 1                               | 2   | 3    | 1                  | 2     | 3            |  |  | 1                                     | 2  | 3  |                        |  |   |              |   |  |
| VGPL 16  | 19 / 20            | 20                                 | 35  | 50  | 0.1                             | 0.3 | 0.5  | -                  | -     | -            | 30                                     | 10   | 90                                    | 85 | 80 | 3 / 4                  | 9 / 12<br>21 / 28 / 16                                       | 36 / 48<br>64 / 84<br>112 / 147<br>196                              |              |   |  |
| VGPL 22  | 19 / 20<br>25 / 26 | 10                                 | 20  | 30  | 0.1                             | 0.5 | 1.5  | 0.008              | 0.006 | 0.004        | 30                                     | 24   |                                       |    |    | 4 / 5                  | 16 / 20<br>28 / 35   | 64 / 80<br>112 / 140<br>196 / 245                                   |              |   |  |
| VGPL 26  | 25 / 26            |                                    |     |     | 20                              | 35  | 50   | 0.3                | 1     | 3            | 0.012                                  | 0.010  |                                       |    |    | 0.095                  | 50   | 40  | 3.5 / 4.33   | 12.25 / 18.78<br>26 / 33.22                             | 81.37 / 112.67<br>143.96 / 199.33                                    |
| VGPL 32  | 32 / 33            | 8                                  | 12  | 15  | 0.4                             | 2   | 6    | 0.015              | 0.012 | 0.011        | 80                                     | 65   |                                       |    |    | 4 / 4.5<br>5.2         | 12.08 / 16<br>18 / 20.8<br>25 / 29<br>32 / 36<br>41.6        | 64 / 72 / 81<br>100 / 130<br>144 / 200<br>225 / 256<br>288          |              |   |  |
| VGPL 42  | 42 / 43            |                                    |     |     | 20                              | 35  | 50   | 0.7                | 4     | 12           | 0.03                                   | 0.024  |                                       |    |    | 0.024                  | 150  | 120   | 3.5 / 4<br>5 | 12.25 / 14<br>16 / 20<br>24 / 25<br>30 / 30.67<br>38.33 | 49 / 56<br>64 / 70 / 80<br>100 / 120<br>144 / 184<br>235.11 / 293.89 |
| VGPL 52  | 52 / 56 / 57       | 6                                  | 12  | 15  | 1.5                             | 10  | 30   | 0.06               | 0.055 | 0.05         | 250                                    | 200  |                                       |    |    | 4 / 4.5<br>5.2 / 6.25  | 12.08 / 16<br>18 / 20.8<br>25 / 29<br>32 / 36<br>41.6 / 50   | 64 / 72 / 81<br>100 / 130<br>144 / 200<br>225 / 256<br>288 / 400    |              |   |  |
| VGPL 80  | 80                 |                                    |     |     | 3                               | 15  | 38   | 0.12               | 0.08  | 0.075        | 400                                    | 320  |                                       |    |    | 3.5 / 4<br>5           | 12.25 / 14<br>16 / 20 / 24<br>25 / 30<br>30.67 / 38.33<br>46 | 49 / 56 / 64<br>70 / 80 / 100<br>120 / 144 / 184<br>235.11 / 293.89 |              |   |  |
| VGPL 105 | 80 / 100           |                                    |     |     | 20                              | 35  | 50   | 12                 | 60    | 150          | 1                                      | 0.85   |                                       |    |    | 0.8                    | 800  | 640   | 3.5 / 4<br>5 | 12.25 / 14<br>16 / 20<br>24 / 25<br>30 / 30.67<br>38.33 | 49 / 56<br>64 / 70 / 80<br>100 / 120<br>144 / 184<br>235.11 / 293.89 |
| VGPL 105 | 126                |                                    |     |     | 25                              | 120 | 150  | 1                  | 0.85  | 0.8          | 800                                    | 640  |                                       |    |    | 3.5 / 4                | 12.25 / 14<br>16 / 20<br>24 / 30.67                          | 49 / 56<br>64 / 70 / 80<br>100 / 120<br>144 / 184<br>235.11         |              |   |  |
| VGPL 120 | 126                | 25                                 | 130 | 350 | 1.75                            | 1.4 | 1.35 | 1500               | 1200  | 3.5 / 4<br>5 | 12.25 / 14<br>16 / 20<br>24 / 25<br>30 | 49 / 56<br>64 / 70<br>80 / 100<br>120 / 144<br>180 |                                       |    |    |                        |  |   |              |   |  |

<sup>1)</sup> no load <sup>2)</sup> center of the shaft <sup>3)</sup> in grease-lubricated operation <sup>4)</sup> continuous operation

<sup>5)</sup> applies to FV, HV, UHVG for type reduced backlash <sup>6)</sup> applies to FV, HV, UHVG for type low backlash <sup>7)</sup> applies to UHVS, UHVC type standard backlash <sup>8)</sup> type standard backlash

Extreme

Stepper Motor with Resolver

In comparison to other resolvers with variable differential rotary transformer, the resolvers R02010 and R03620 use a constant air gap. They are less sensitive to eccentricity and magnetic stray fields and can directly be connected to standard resolver-to-digital-(R/D)-converters.

The resolver is suitable for the use in ultra high vacuum and cryogenic environment – UHVC2 (4K) class available on request.

Accuracy:  $\pm 60$  arcmin (1 °)

Kapton leads, 500 mm long

Sense of Rotation

Positive when CCW seen from leads outlet

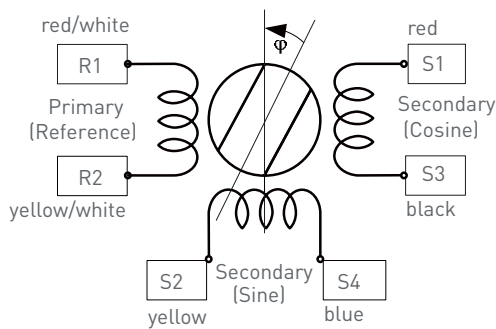

|    |      | No |
|----|------|----|
| R1 | Ref+ | 1  |
| R2 | Ref- | 2  |
| S1 | Cos+ | 3  |
| S3 | Cos- | 4  |
| S2 | Sin+ | 5  |
| S4 | Sin- | 6  |

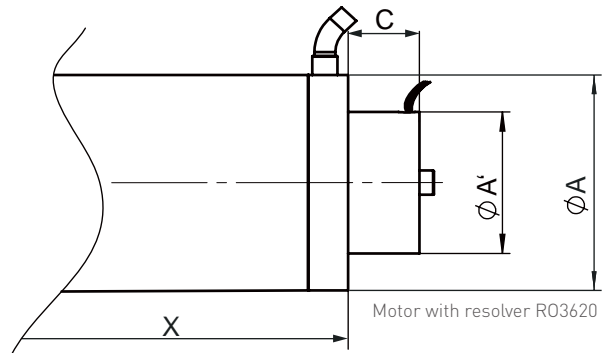

Resolver Specification

| Resolver | Stepper motor              | A   | A'                 | C    | X            | Electrical Characteristics                  |                            |                      |                                   |                     |    |
|----------|----------------------------|-----|--------------------|------|--------------|---|----------------------------|----------------------|-----------------------------------|---------------------|----|
|          |                            |     |                    |      |              | Excitation amplitude [V <sub>r.m.s.</sub> ] | Excitation frequency [kHz] | Transformation ratio | Rotor inertia [gcm <sup>2</sup> ] | Mass [g] [Resolver] |    |
| R02010   | VSS 25<br>VSS 26           | 25  | 20                 | 17.5 | 33.5<br>49.5 | 2 to 12                                     | 5 to 50                    | 0.5<br>± 10 %        | 1                                 | 30                  |    |
| R02010   | VSS 32<br>VSS 33           | 32  |                    |      | 41<br>60     |   |                            |                      |                                   |                     |    |
| R03620   | VSS 42<br>VSS 43           | 42  | 56.5<br>71.5       |      |              |   |                            |                      |                                   |                     |    |
| R03620   | VSS 52<br>VSS 56<br>VSS 57 | 52  | 66<br>59.1<br>75.1 |      | 10.9         |   |                            |                      |                                   |                     | 85 |
|          |                            | 56  |                    |      |              |   |                            |                      |                                   |                     |    |
|          |                            | 57  |                    |      |              |   |                            |                      |                                   |                     |    |
| R03620   | VSH 80                     | 80  | 103.5              |      |              |   |                            |                      |                                   |                     |    |
| R03620   | VSH 100                    | 100 | 127.5              |      |              |   |                            |                      |                                   |                     |    |
| R03620   | VSH 126                    | 125 | 216.5              |      |              |   |                            |                      |                                   |                     |    |

## Resolver - Encoder Converter



Phytron ID: # 10011284

The position data converter controls autonomously the resolver sensor and converts the output signals of the resolver to incremental output signals (square wave signal).

Resolution: 1024 increments

Output reference signal: 8 V<sub>PP</sub> (diff.)  
100 mA max.  
10 kHz

Input SIN/COS: 4 V<sub>PP</sub> (max.)

Resolver transformation factor: K= 0.5

Supply voltage: 24 V (14...36 V<sub>DC</sub>)

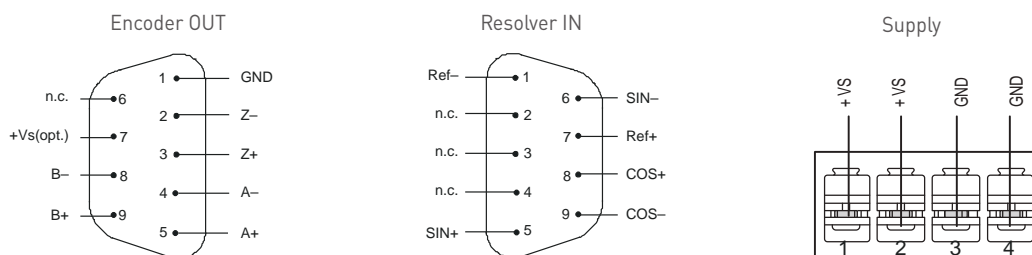

Phytron's modular *phyMOTION*<sup>™</sup> controller evaluates the resolver signals directly with the newly developed resolver evaluation module ECMS01.

## Thermocouple Type K and Resistance Temperature Detector Pt100

The insulated temperature sensor in Phytron motors is integrated in the motor windings. The response time to temperature changes of the winding is very short, compared to temperature sensors mounted outside the motor housing. The temperature is measured all the time (even only one motor phase is powered at any time), because the sensors are always mounted between the phases.

### Thermocouple element type K

Phytron uses with the Type K (NiCr-Ni) in-vacuum and cryo stepper motors, thermal elements in the temperature range from -270 to +1370 °C, accuracy class 1. The Type K is a metal thermal element with nickel-based alloy conductors. Temperature ranges, accuracy and characteristics of thermal elements for industrial use are defined in the IEC 584 standard (temperature measuring with thermal elements)

The accuracy of the temperature measuring depends on the temperature of the reference point.

### Resistance temperature detector (RTD) Pt100

Phytron uses Pt100 resistor sensors in in-vacuum and cryo stepper motors in the temperature range -200 to +300 °C. These precise sensors are used in extreme industrial and laboratory conditions. They consist of a wound resistance wire that is mounted and unsupported inside a cylindrical ceramic case

The evaluation of the temperature measuring is possible with the corresponding module in the *phyMOTION*<sup>™</sup> controller. For the K type variations to some degree are possible.

### Phytron devices and controllers for the evaluation of Pt100 resistor sensors and thermal element type K

1-axis controller MCC-1  
2-axes controller MCC-2  
Multi-axes controller *phyMOTION*<sup>™</sup>

Extreme

Option: Shaft Design with Flat Surface

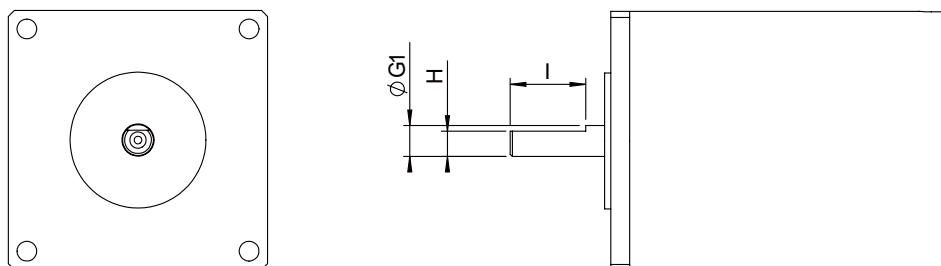

Dimensions

| Stepper motor    | Dimensions in mm |     |      |
|------------------|------------------|-----|------|
| Typ              | G1               | H   | l    |
| VSS19            | 2,5              | 2   | 4,5  |
| VSS25<br>VSS26   | 3                | 2,5 | 6,5  |
| VSS32<br>VSS33   | 4                | 3,5 | 8    |
| VSS 42<br>VSS 43 | 5                | 4   | 13   |
| VSS 52           | 6                | 5   | 14   |
| VSS 56<br>VSS 57 | 6,35             | 5,5 | 18,5 |

More shaft options on demand.

Torque Characteristics

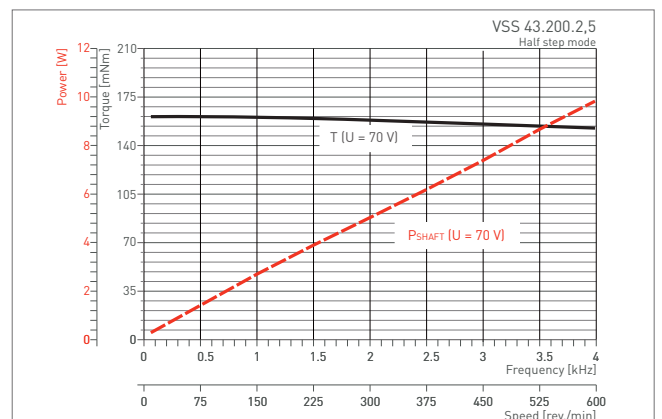
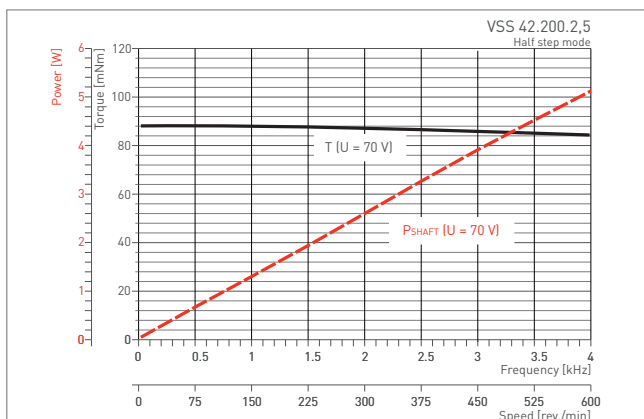
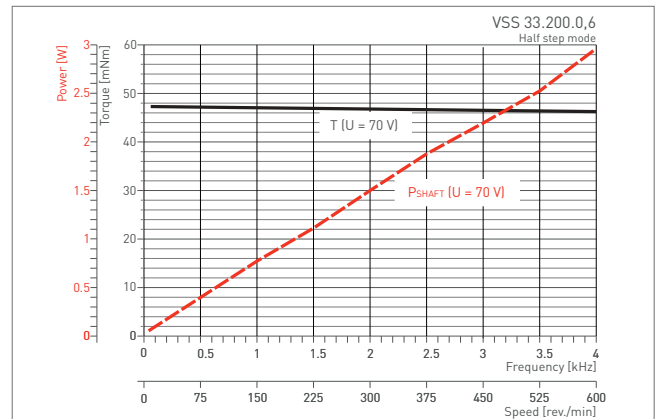
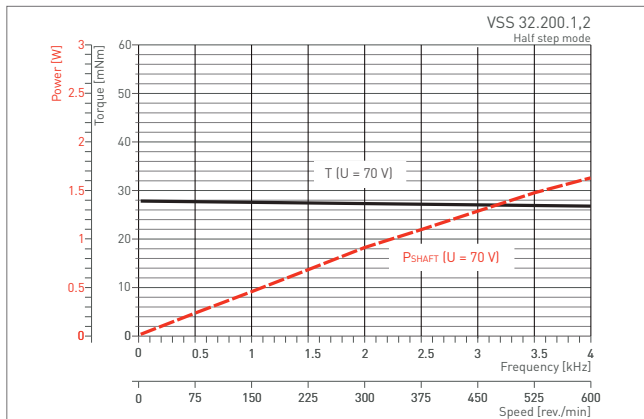
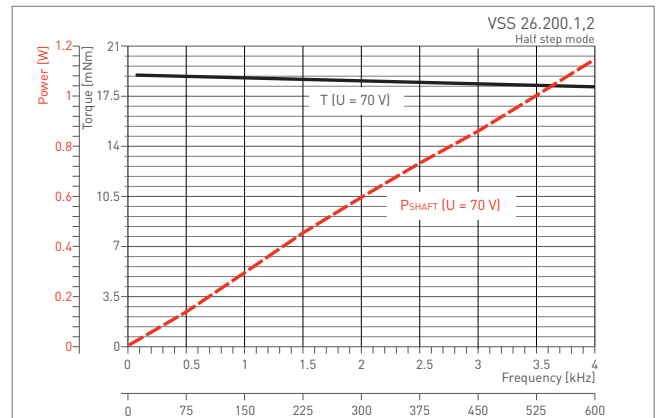
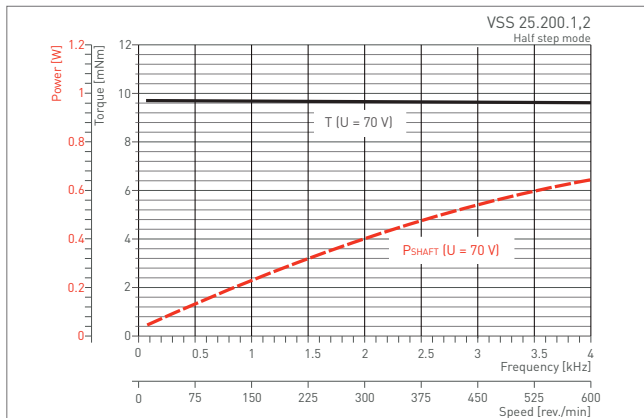
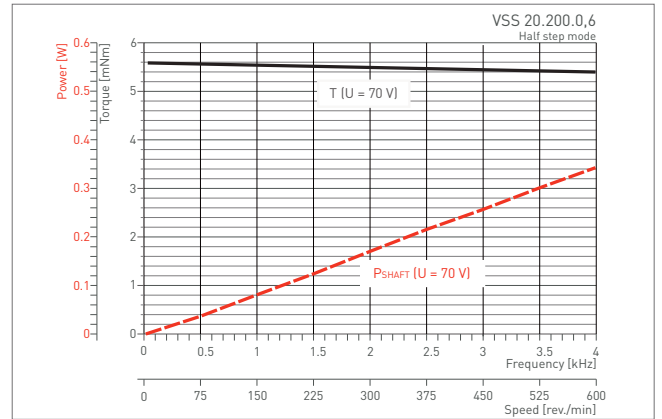
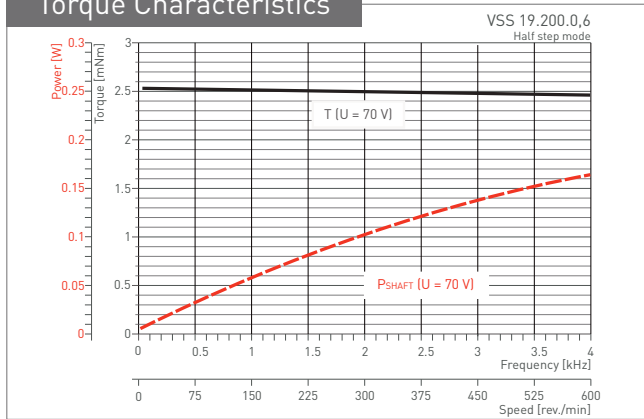

Extreme

Torque Characteristics

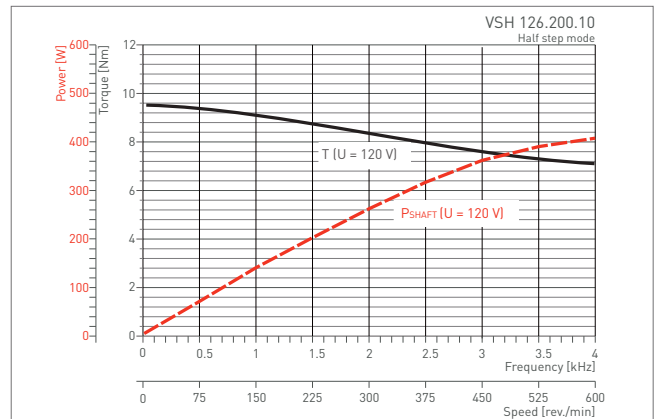
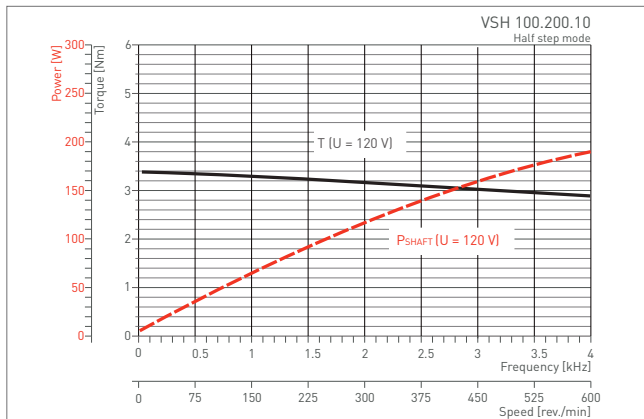
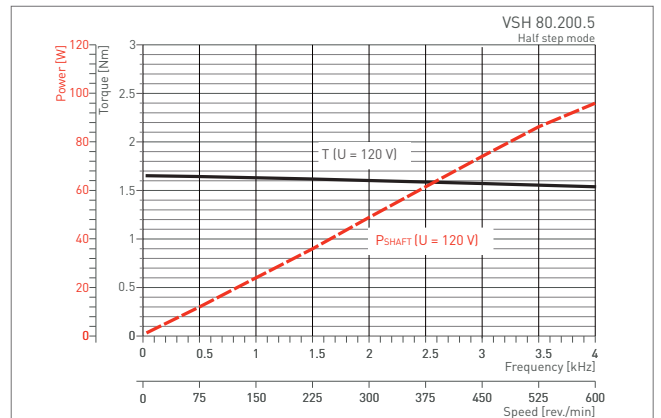
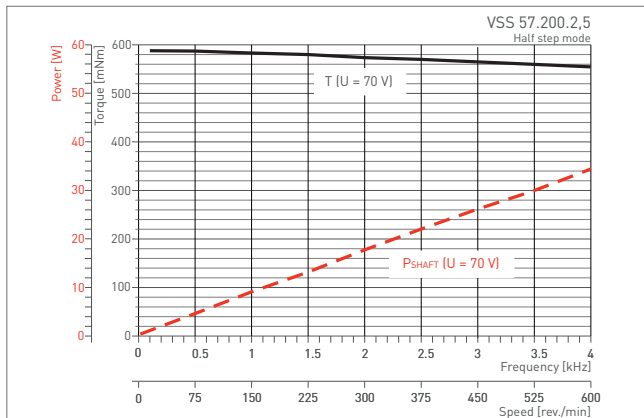
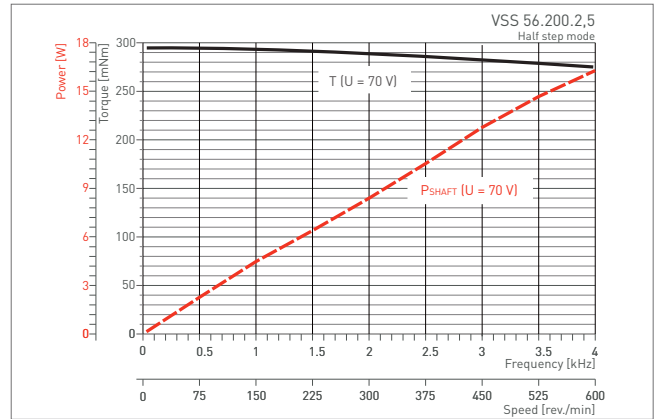
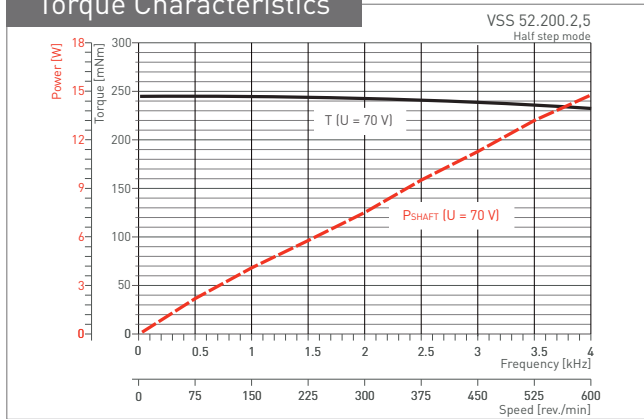

U = 70 V<sub>DC</sub> / 120 V<sub>DC</sub>: Operating voltage of the power stage (intermediate circuit voltage)

## Efficient Customising - the Perfect Fit

### Combine efficiently standard components, modifications & specials

For 30 years we have used our know-how in a lot of successful space projects to optimise our vacuum series for industrial and scientific applications in the matter of performance and cost efficiency. The specific designs of the two-phase hybrid stepper motors have been designed for use in vacuum up to  $10^{-11}$  hPa. Phytron vacuum stepper motors are conditioned at up to 250 °C for use in the high-(HV) or ultra-high vacuum (UHV) and are designed dependent on the applications for the low-temperature range up to -196 °C (N<sub>2</sub>), -269 °C (He), or high-temperature range (winding temperature up to +300 °C) and, if necessary, also for radiation up to  $10^6$  J/kg.

Starting from the VSS/VSH series we have already implemented a number of customer specific projects. Performance, housings, flanges, materials, shaft machining – in the common specification process, the VSS/VSH platform can be optimised for your project. With our high in-house production depth we are not only technologically very flexible, we can also produce small quantities.

### Applications

Our vacuum motors, power stages or controllers are driving in a lot of different applications:

- Particle accelerators and X-ray measuring systems (PETRA III, PANTER, FERMI, PAL, SOLEIL,...)
- Devices for molecular analysis
- Electron microscope
- Sputtering systems
- Cryostats
- Mass spectrometry

### Stepper motor spindle version for a particle accelerator (Cavity Tuner)

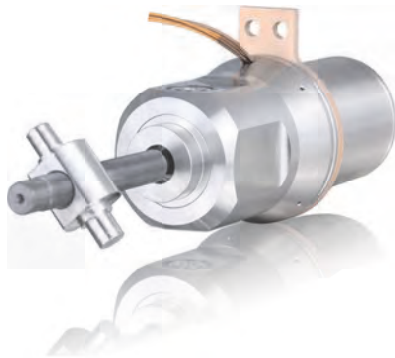

#### Adjustment of particle accelerator cavities

- stepper motor with 200 steps/revolution (1.8°), with integrated gear 50:1 (10:000 steps/revolution)
- designed for 1300 N axial force
- spindle and nut system, non-magnetic
- material for housing, flanges and internal parts stainless steel or titanium
- dry lubricated for usage under vacuum at -270 °C up to +40 °C (also as grease lubricated version for environments > 35 °C)
- optional EMC cable shielding
- thermocouple K-type in winding

## Extreme

Motion Controller for Vacuum Application: *phyMOTION™*

## Modular stepper motor controller for in-vacuum applications

The *phyMOTION™* controller is ideally equipped for the demands of in-vacuum projects. Beside the encoder evaluation (differential incremental encoder with quadrature signals, absolute encoder acc. to SSI standard, BiSS- and EnDat-encoder) a resolver and temperature sensor evaluation of each axis is possible for monitoring of the driven motors. This functions can be integrated as optional submodules of each axis – in addition to the default limit switch evaluations of each axis. The better part of cabling effort is eliminated because the power stages are already integrated.

You can combine with 6 to 21 modules of each housing up to 18 power stages with different functions (axis modules, digital I/O, analogue I/O, 4-axis indexer for interpolation, integrated display)

Via freely selectable HOST interface (ProfiBus, ProfiNet, Ethernet, RS232, RS485, USB, Bluetooth) and provided drivers and protocols (LabVIEW® VI, EPICS) you can seamlessly integrate the *phyMOTION™* also below existing systems.

Operate the *phyMOTION™* as free programmable stand-alone controller, as distributed intelligence, or also as a slave system i.e. below existing PLC systems.



Encoder types suitable for the **encoder evaluation**:

- Differential incremental encoder with Quadratic signals
- Absolute encoder acc. to SSI standard
- BiSS encoder
- EnDat encoder
- Resolver

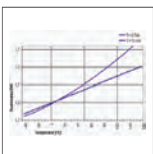

Temperature evaluation module for **stepper motor temperature monitoring**

Thermal elements type K or Pt100 resistor sensors can be used. The insulated temperature sensor in Phytron motors is integrated in the motor windings. The response time is very short. The temperature is measured all the time, even if only one motor phase is powered at any one time.



Control via Android-based integrated touch panel (TPM01) or via Android-based tablets (from version V4.0)

- As user interface i.e. for parameter selection
- For support, parameterisation and diagnostics



**LabVIEW®-VI**

VIs for *phyMOTION™* – simulation software with graphical style

Use the VIs (Virtual instruments) generated by Phytron and integrate them in your LabVIEW® project. So you can easily control the phytron controller *phyMOTION™* from your usual programming environment.

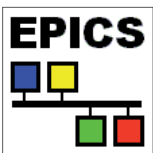

Software environment to develop and realise distributed control systems for large-scale experiments such as telescopes and accelerators. EPICS provides the SCADA support.

Phytron delivers the source code to integrate the Phytron controller *phyMOTION™* into EPICS environment. Also in multi-axis operation: positioning, limit switches, encoder evaluation

Extreme

Electrical Connection

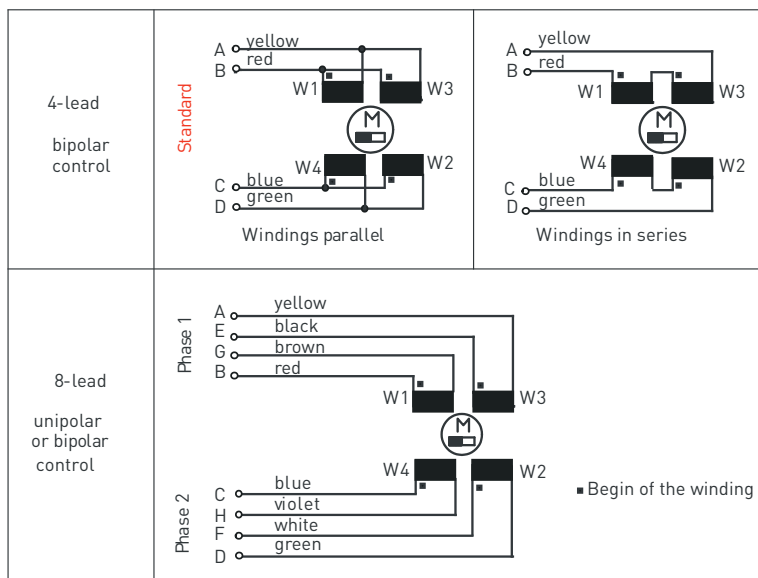

All illustrations, descriptions and technical specifications are subject to modifications; no responsibility is accepted for the accuracy of this information.

Ordering Code

The variable elements of the product are displayed in colour.

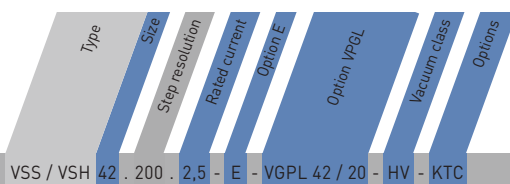

Ordering code VSS / VSH 42 . 200 . 2,5 - E - VGPL 42 / 20 - HV - KTC

| Options                 |                                      |  |
|-------------------------|--------------------------------------|--|
| Size                    | 19 - 125                             |  |
| Rated current [A/Phase] | 0,6<br>1,2<br>2,5<br>5<br>10         | for VSS 19 to 33<br>for VSS 19 to 57<br>for VSS 42 to 57<br>for VSH 80<br>for VSH 100 to VSH 126   |
| Option E                | E                                    | Double shaft<br>no double shaft  |
| Option VGPL             | VGPL xx/xx                           | Low backlash gear: size / reduction ratio<br>no gear   |
| Vacuum class            | HV<br>UHVS<br>UHVG<br>UHVC1<br>UHVC2 | High vacuum<br>Ultra high vacuum dry coated bearing<br>Ultra high vacuum greased bearing<br>Ultra high vacuum Cryo temperature down to liquid Nitrogen<br>Ultra high vacuum Cryo temperature down to liquid Helium |
| Options                 | R<br>KTC<br>Pt<br>RS<br>X            | Radial wire outlet<br>Thermocouple type K <sup>*)</sup><br>Resistance temperature detector<br>Resolver<br>customised<br>no   |

\*) Standard for vacuum class UHVS and UHVG.

Phase Currents

| Admissible phase currents for identical power dissipation |                                 |
|---|---------------------------------|
| Bipolar control mode Full step operation                  |                                 |
| 4-lead motor  | 4-lead motor                    |
| parallel windings   | series windings                 |
| <b>rated current</b>                                      | <b>50% of the rated current</b> |

**Morskate®**



Any questions? Please contact us.

**Morskate Aandrijvingen BV**

Oosterveldsingel 47A  
7558 PJ Hengelo (Ov)  
The Netherlands

NL

T +31 (0)74 - 760 11 11  
info@morskateaandrijvingen.nl  
www.morskateaandrijvingen.nl

DE

T +49 692 - 222 34 95  
info@morskateantriebstechnik.de  
www.morskateantriebstechnik.de

EN

T +31 (0)74 - 760 11 11  
info@morskatedrivetechnology.com  
www.morskatedrivetechnology.com