



phyMOTION™ Modular multi-axes controller for stepper motors

The phyMOTION™ combines PLC and motion control functions into a flexible and convenient framework for multi axis stepper motor applications. The free software phyLOGIC™ Toolbox, the LabVIEW interface, the Android-based touch interface (internal/external) and the open protocol for controller drive and parameterising create additional scope for development. The integra-

ted, high resolution power stages up to 15 A_{Peak} at 120 V_{DC} simplify the wiring significantly.

Designed for Industry 4.0

The phyMOTION™ can be operated below existing PLC systems as a slave system, as distributed intelligence or as a stand-alone motion control solution. Online parameterising and -diag-

nostics are also standard feature as limit switch/reference switch inputs per axis. Each axis can be expanded with encoder (Endat, SSI- /Quadrature) and temperature evaluation. Besides standard PLC functions such as analogue and digital I/Os, a variety of interfaces (Ethernet, Profibus, Profinet, RS232/485, USB) the phyMOTION™ also provides linear and circular interpolation.

In 4 steps to your stepper motor controller

1 Choose the phyMOTION™ type

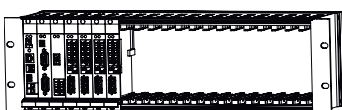

Housing depth s

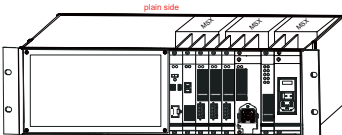

Housing depth p

ext int	external	6SL-s, 8SL-s, 10SL-s or 21SL-s	integrated external	Rack, wall, rail mounting or bench	POWM01+MCM01 or MCM02
	internal 115 V _{AC} to 230 V _{AC}				
	Supply / Mains connection	Housing width	Touch Panel	Type of mounting	Supply
int	internal 115 V _{AC} to 230 V _{AC} Definition of the motor voltages*)	21SL-p	integrated external	Definition of the fitting position <ul style="list-style-type: none"> • connection side • plain side 	Bench, rack or rack-inverse POWM03+MCM01 or MCM03

*) 3 supply modules 500 W each can be combined; also with different motor voltages (48 V, 70 V, 120 V).

2 Define host interface: Ethernet, ProfiBus/ProfiNet, RS 485, RS 232, RS 422

3 Select the modules

4 Order and receive the fully assembled phyMOTION™

Any questions? Please call us! Together we will find your desired configuration: 0049-8142-503250

Module selection for your *phyMOTION*TM

To make the module selection as comfortable as possible, we coded the modules by main and auxiliary functions.

CPU This main function is included in the respective module.

CPU The main function is not available in the respective module.

I/O D Auxiliary functions are shown only if the module supports them.

POWER STAGE * * means the main or auxiliary function is selectable as option.

ENC *

Main functions	POWER SUPPLY	The POWER SUPPLY function is marked when there is a power supply in the module (power supply unit).		
	CPU	Modules with CPU contain intelligent processors and can execute the total sequential programs and enable the <i>phyMOTION</i> TM to drive in stand-alone mode.		
	INDEX	The INDEXER represents the functionality to generate signals from commands of a programming language, which the power stage can amplify. Normally, the signal is control pulses/direction or SIN/COS.		
	POWER STAGE	POWER STAGE represents a stepper motor amplifier. Incoming control pulses/direction or SIN/COS signals are amplified and output to the motor..		
Auxiliary functions	ENC	Encoder evaluation	POW IN	Power distribution
	TEMP	Motor temperature evaluation	COM	Host interface
	I/O D	Digital inputs and/or outputs	SAFETY	Safe Torque Off
	I/O A	Analogue inputs and/or outputs		
	...			

Options for your *phyMOTION*TM

Options are available for the main or auxiliary functions. The following overview will make the option selection as easy as possible:

POWER STAGE *

Option selectable power stage

- APS power stage (APS01):
 - step frequency up to 500.000 steps/sec.
 - up to 5 A_{PEAK} at 24 to 70 V_{DC} (Derating dep.on application)
 - precision up to 1/512 step resolution
 - Sinusoidal current curve
 - Overdrive function (a motor independent compensation of the phase current decrease in the upper speed range)
- LPS power stage (LPS01):
 - step frequency up to 250.000 steps/sec.
 - up to 9 A_{PEAK} at 24 to 70 V_{DC} (Derating dep.on application)
 - precision up to 1/256 step resolution
 - Sinusoidal-like current curve

ENC *

Option selectable encoder evaluation

Encoder type	supply	resolution	supported types	option (submodule)			
				ECAS01	ECES01	ECBS01	ECMS01
differential	5 V / 5.5 V 500 mA	2 ³²	Quadrature with zero track	✓	✓	✓	
SSI	5 V / 5.5 V 500 mA	2 ³¹	SSI	✓	✓	✓	
BiSS	5 V / 5.5 V 500 mA	2 ³¹	BiSS-C BiSS-B			✓	
EnDat	5 V / 5.5 V 500 mA	2 ³¹	Endat 01 02 21 22 T		✓		
Resolver	5 to 10 V _{rms} 1 to 10 kHz	2 ¹²	Resolver 6-wire LVDT / RVDT 4-/5-/6-wire				✓

TEMP *

Option selectable motor temperature evaluation

- with KTS01 submodule: the stepper motor temperature is evaluated with the metall thermocouple type K by comparison measurement
- with PTS01 submodule: the stepper motor temperature measurement with the Pt resistor sensors

1 Housing and Supply

Housing types of the phyMOTION™:

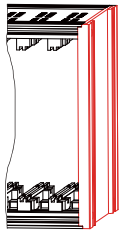

Bench or rail mounting

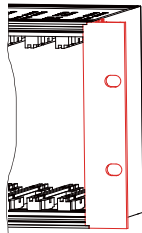

Rack mounting (connection side is the front)

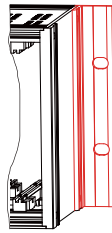

Wall mounting or rack-inverse (like rack mounting, but connection side is back)

Housing depth / current supply	Slots	U	Width	Height	Depth	Mounting
s / external or s / internal	6	24	137	132.5	121	R/W/MR/D
	8	32	177.6			
	10	40	218.3			
	21	84	442.4			
p / internal	21	84	442.4	132.5	360	R/RI/D

dimensions in mm
Mounting bracket for rack, rack-inverse or wall mounting: +40.6 mm

Ordering code s / „ext“

Type	Number of slots	Mounting	Housing dep.	customised
phyMOTION	6SL	MR	s	X
Options				
number of slots	6SL 8SL 10SL 21SL	6 slots 8 slots 10 slots 21 slots (=19")		
mounting	W MR R D	wall mounting rail 19" sub rack bench		
housing depth	s	small		
customised	X	customer demand		

Type	Number of slots	Mounting	Housing dep.	customised
phyMOTION	21SL	RI	p	X
Options				
number of slots	21SL	21 Slots (=19")		
mounting	R RI D	19" sub rack rack-inverse bench		
housing depth	p	power		
customised	X	customer demand		

Type	Number of slots	Mounting	Housing dep.	customised
phyMOTION	21SL			
Options				
number of slots	8SL 10SL 21SL	8 slots 10 slots 21 slots (=19")		
mounting	W MR R D	wall mounting rail 19" sub rack bench		
housing depth	s	small		
customised	X	customer demand		

Main Supply (POWM01)

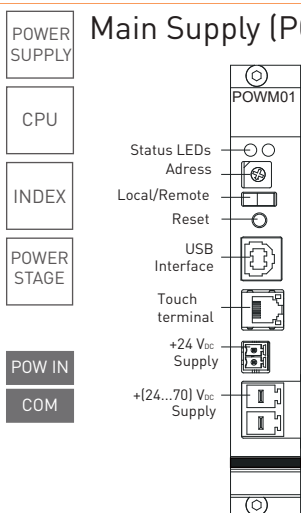

The beginning of each phyMOTION™

- Main supply:
 - 24 to 70 V_{DC} supply voltage (for motors and generates internally the logic voltages) – max. 20 A
 - Electrically isolated 24 V_{DC} for inputs/outputs, limit and reference switches
- Configuration
 - USB interface for programming and diagnostics
 - Device address switch
 - Reset key
 - Connection of an external Phytron touch panel
- The external supply must be designed for the required current (e.g. by the PS5-48 power supply unit).

Type

Industrial

POWER SUPPLY

CPU

INDEX

POWER STAGE

POW IN

Intermediate Supply (POWM02)

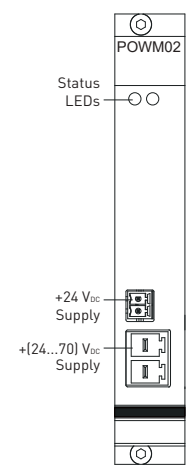

Maximum 20 A per supply

- 24 to 70 V_{DC} supply voltage (for motors and generates internally the logic voltages) – max. 20 A
- Electrically isolated 24 V_{DC} for inputs and outputs, limit and reference switches
- The external supply must be designed for the required current (e.g. by the PS5-48 power supply unit).

ext

s

Ordering Code

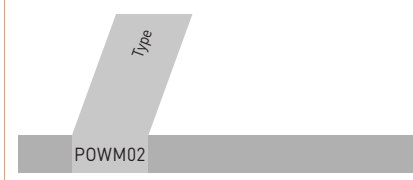

Mating connectors are included in delivery.

POWER SUPPLY

CPU

INDEX

POWER STAGE

POW IN

COM

Main Supply (POWM03)

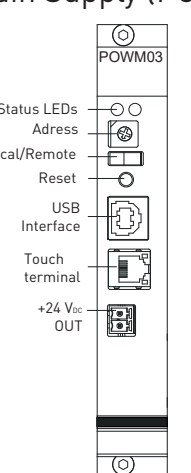

The main supply of the phyMOTION™

- Configuration
 - USB interface for programming and diagnostics
 - Device address switch
 - Reset key
 - Connection of the external Phytron touch terminal (TPE)
- 24 V_{DC} output (for e.g. sensors)

int

s/p

Ordering Code



Mating connectors are included in delivery.

POWER SUPPLY

CPU

INDEX

POWER STAGE

POW IN

Intermediate Supply (POWM04)

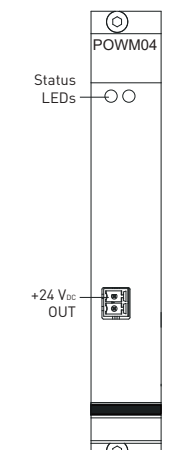

Maximum 20 A for subsequent power stages (except MSX)

- 48 to 70 V_{DC} Power supply (for motors and generates internally the logic voltages) – max. 20 A
- 24 V_{DC} output (for e.g. sensors)

int

s/p

Ordering Code

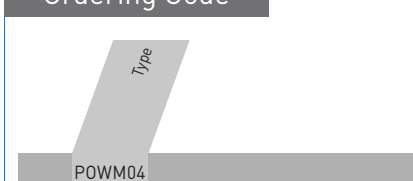

Mating connectors are included in delivery.

POWER SUPPLY

CPU

INDEX

POWER STAGE

115 to 230 V Power Supply (NETM02)

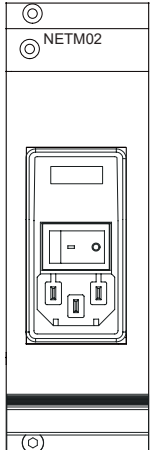

External mains voltage (115 V to 230 V)

- Mains switch
- 115 V to 230 V mains voltage
- internal supply of the phyMOTION™ with motor and logic voltage
- per 500 W defined motor voltage (max. 3)

int

s/p

Ordering Code

<i>Type</i>	<i>Motor voltage 1</i>	<i>Motor voltage 2</i>	<i>Motor voltage 3</i>
NETM02	70V	70V	48V

Options		
Motor voltage	48 V 70 V 120 V	500 W each defined motor voltage (max. 3)

POWER SUPPLY

CPU

INDEX

POWER STAGE

Supply of the Intermediate Circuit Voltage (SUPM)

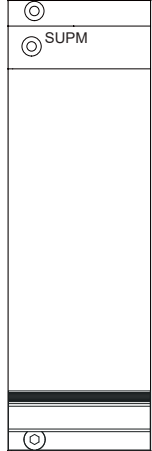

Power supply for intermediate circuit voltage (24, 48, 70 and 120 V_{DC})

- generates the internal supply of the phyMOTION™ with motor and logic voltage from the mains voltage
- Options depend on housing depth:
 - SUPM02, 04 and 07 (with front panel) with housing depth s
 - SUPM08 and 12 (without front panel) with housing depth p

int

s/p

Ordering Code

<i>Type</i>	<i>intermediate circuit voltage</i>
SUPM	02

Options		
intermediate circuit voltage	02 04 07	24 V housing s 48 V housing s 70 V housing s
	08 12	70 V housing p 120 V housing p

POWER SUPPLY

CPU

INDEX

POWER STAGE

External Power Supply Unit (SPH)

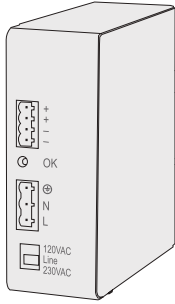

Compatible Power Supply Unit (5 to 20 A)

- Mains supply voltage 115 / 230 V_{AC}
- Internally fused mains input
- Output voltage
24 V_{DC} (10 A / 20 A), 48 V_{DC} (5 A / 10 A / 20 A), 72 V_{DC} (6.7 A / 13.5 A)
- Permanently short circuit-proof output
- Overvoltage protection primary and secondary side
- Overtemperature protection
- Integrated fan
- Dimensions (WxHxD) SPH240: 45 x 125 x 121
SPH500: 82 x 125 x 121
SPH1013: 66 x 230 x 183
- DIN rail or wall

ext

s

Ordering Code

<i>Type</i>	<i>Output power</i>	<i>Output</i>	<i>Mounting</i>
SPH1013-4821			W

Options		
Output power - Output	240-2410 240-4805 500-2420 500-4810 500-7207 1013-4821 1013-7214	24 V _{DC} / 10 A 48 V _{DC} / 5 A 24 V _{DC} / 20 A 48 V _{DC} / 10 A 72 V _{DC} / 6.7 A 48 V _{DC} / 20 A 72 V _{DC} / 13.5 A
Mounting	H W	Rear DIN rail Rear wall

Mating connectors are included in delivery.

Industrial

2 Host Interface

Main Controller (MCM01)

Intelligent CPU and bus:

- Main CPU:
 - Controls and administers up to 64 modules
 - Program and register memory up to 4 MB
 - Internal memory expandable with future memory modules
 - Script program administration
 - Firmware administration
 - Elegant programming with *phyLOGIC™* and G-Code
- Selectable communication interface:
 - Ethernet
 - ProfiBus/ProfiNet
 - RS 485, RS 232, RS 422

Options		
Host communication	ETHS01 PBS01 PNS01 RSS01 NNS01	Ethernet ProfiBus ProfiNet RS 232 or RS 485/422 no interface

Main Controller (MCM02)

Intelligent CPU, bus and supply:

- Main CPU:
 - Controls and administers up to 64 modules
 - 24 to 70 V_{DC} supply voltage
 - Mini USB interface
 - Program and register memory up to 4 MB
 - Internal memory expandable with future memory modules
 - Script program administration
 - Firmware administration
 - Elegant programming with *phyLOGIC™*
- Selectable communication interface:
 - Ethernet
 - ProfiBus/ProfiNet

Options		
Host communication		

Main Controller and Supply (MCM03)

Intelligent CPU, bus and for internal supply:

- Main CPU:
 - Controls and administers up to 64 modules
 - Program and register memory up to 4 MB
 - Internal memory expandable with future memory modules
 - Script program administration
 - Firmware administration
 - Elegant programming with *phyLOGIC™*
- Selectable communication interface:
 - Ethernet, ProfiBus/ProfiNet
- 24 V_{DC} output (for e.g. sensors)

Options		
Host communication		

3 Power Stages and Indexer

POWER SUPPLY

CPU

INDEX

POWER STAGE *

ENC *

TEMP *

1 Axis Stepper Motor Drive I1AM01 or I1AM02

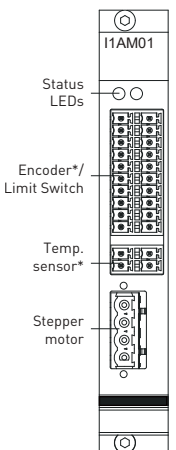

Indexer with integrated 3.5 A power stage (I1AM01) or selectable power stage (I1AM02)*

- Integrated indexer for standard functions:
 - Relative and absolute positioning
 - Reference movements/speed mode
 - Step frequency to 40,000 steps/second
- I1AM01: Integrated 3.5 A power stage
 - 3.5 A_{PEAK} at 24 to 48 V_{DC} (derating dep. on application)
 - Selectable step resolution up to 1/256 step
 - Online power stage parameterisation and diagnostics
- I1AM02: with selectable power stage^{*)}
- 3 limit/reference switches
- Optional encoder evaluation^{*)}
 - SSI, differential, BiSS or Endat; Resolver
- Optional motor temperature evaluation
 - for Pt100 sensors (PTS01) or K types (KTS01)

Ordering Code

Type Power stage Encoder evaluation Temperature evaluation

I1AM02 - APS01 - ECAS01 - PTS01

Options		
1 Axis drive type	I1AM01 I1AM02	with int. 3.5 A power stage with select. power stage
Power stage	APS01 LPS01	with power stage 5 A / 70 V with power stage 9 A / 70 V with power stage 3.5 A / 48 V (I1AM01)
Encoder evaluation	ECES01 ECAS01 ECBS01 ECMS01	ENDAT encoder SSI/QUADR. encoder BiSS Resolver no encoder module
Temperature evaluation	PTS01 KTS01	Pt sensor K type no temperature module

Mating connectors are included in delivery.

POWER SUPPLY

CPU

INDEX

POWER STAGE

ENC *

1 Axis Stepper Motor Drive (I1EM02)

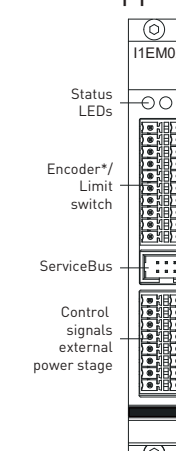

Indexer for external power stage

- Integrated indexer for standard functions:
 - Relative and absolute positioning
 - Reference movements/speed mode
 - Online power stage parameterisation and diagnostics
- Outputs Control pulses/Direction/Boost and Enable to an external power stage
- 3 limit/reference switches
- Optional encoder evaluation^{*)}
 - SSI, differential, BiSS or Endat; Resolver

Ordering Code

Type Encoder evaluation

I1EM02 - ECAS01

Options		
Encoder evaluation	ECES01 ECAS01 ECBS01 ECMS01	ENDAT encoder SSI/QUADR. encoder BiSS Resolver no encoder module

Mating connectors are included in delivery.

POWER SUPPLY

CPU

INDEX

POWER STAGE

4 Axes High End Indexer (I4XM01)

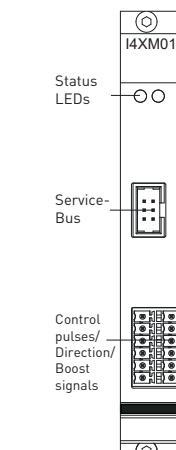

Indexer module

- 1, 2, 3 and 4 axes stepper motor indexer
- Circular interpolation for 2 any axes
- Linear interpolation for 4 axes (also for reduction gears axes)
- Additional Control Pulses/Direction input and output for "electronic wave"
- Expanded indexer functions:
 - Velocity/end position during the movement changeable
 - Variable, short ramps; high velocities
 - Interpolation also for gear axes
 - High speed: up to 500,000 steps/second
 - ...

Ordering Code

Type

I4XM01

Mating connectors are included in delivery.

* refer to page 2

Industrial

1 Axis Carrier Module for APS-/LPS Power Stage (INAM01)

POWER SUPPLY
CPU
INDEX
*** POWER STAGE**
ENC *
TEMP *

Status LEDs
Encoder*/ Limit Switch
Temp. sensor*
Stepper motor

APS/LPS, encoder and temperature

- Requires an upstream installed indexer for interpolation (i.e. I4XM01)
- Selectable high end power stage*)
- 3 limit/reference switches
- Optional encoder evaluation*)
- SSI, differential, BiSS or Endat; Resolver
- Optional motor temperature evaluation
- For Pt100 sensors (PTS01)
- K types (KTS01)

Ordering Code

INAM01 - APS01 - ECAS01 - PTS01

Options		
Power stage	APS01 LPS01	Int. power stage 5A/70V Int. power stage 9A/70V
Encoder evaluation	ECES01 ECAS01 ECBS01 ECMS01	ENDAT encoder SSI/QUADR. encoder BiSS Resolver no encoder module
Temperature evaluation	PTS01 KTS01	Pt sensor K type no temperature module

Mating connectors are included in delivery.

Power Stage Module with Safe Torque Off (INSM01)

POWER SUPPLY
CPU
INDEX
*** POWER STAGE**
ENC *
SAFETY

Status LEDs
Encoder*/ Limit Switch
STO Input
Stepper Motor

APS, STO and Encoder

- with Safe Torque Off function SIL3/Plc
- Currently the high end power stage APS01 can be selected
- Up to 5 A_{peak} for 24 to 70 V_{DC} (derating dep. on application)
- Precision up to 1/512 step resolution
- Online parameterisation and diagnostics
- 3 limit/reference switches
- Optional encoder evaluation*)
- SSI, differential, BiSS or Endat; Resolver (refer to page 2)

Ordering Code

INSM01 - APS01 - ECAS01

Options		
Power stage	APS01	Int. power stage 5A/70V
Encoder evaluation	ECES01 ECAS01 ECBS01 ECMS01	ENDAT encoder SSI/QUADR. encoder BiSS Resolver no encoder module

Mating connectors are included in delivery.

1 Axis Module for integrated MSX+ Power Stage (INAM03)

POWER SUPPLY
CPU
INDEX
*** POWER STAGE**
ENC *
TEMP *

Status LEDs
Encoder*/ Limit Switch
Temp. sensor*
Stepper motor

MSX+ Power stage, encoder and temperature

- Requires an upstream installed indexer for interpolation (i.e. I4XM01)
- Currently the high end power stage MSX+ can be selected
- Up to 15 A_{PEAK} for up to 120 V_{DC}
- Precision up to 1/20 step resolution
- (5+1) pin motor connector with PE
- 3 limit/reference switches
- Optional encoder evaluation*)
- SSI, differential, BiSS or Endat; Resolver
- Optional motor temperature evaluation
- For Pt100 sensors (PTS01)
- K-types (KTS01)

Ordering Code

INAM03 - MSX+ - ECAS01 - PTS01

Options		
Power stage	MSX+	Power stage up to 15 A/70 V
Encoder evaluation	ECES01 ECAS01 ECBS01 ECMS01	ENDAT encoder SSI/QUADR. encoder BiSS Resolver no encoder module
Temperature evaluation	PTS01 KTS01	Pt sensor K type no temperature module

Mating connectors are included in delivery.

* refer to page 2

Indexer Interface (EXAM01) for External Power Stage

Interface between indexer and external power stages

- Requires an upstream installed indexer (i.e. I4XM01)
- Outputs Control pulses/Direction/Boost and Enable to an external power stage
- External power stages with ServiceBus can be parameterised online by the interface on the indexer module (i.e. I4XM01) and be diagnosed.
- 3 limit/reference switches
- Optional encoder evaluation¹⁾
 - SSI, differential, BiSS or Endat; Resolver
- Optional motor temperature evaluation
 - for Pt100 sensors (PTS01) or K types (KTS01)

I/Os (analogue/digital)

PID Regulation Module (PIDM01)

Proportional, Integral, Derivative Regulation Module

- 4 analogue measuring inputs i.e. for Pt100 sensors and K types
- 4 digital inputs 24 V
- 4 digital outputs 24 V, max. 1 A
- 24 V supply of the I/O is centrally delivered either by the power modules or directly at the PIDM01
- 4 independent PID controllers with PWM output

Digital I/Os (DIOM01)

Digital I/O module

- 8 digital inputs 24 V_{DC}
- 8 digital outputs 24 V_{DC}, max. 1 A
- 24 V supply of the inputs and outputs is centrally delivered either by the power modules or directly at the DIOM01.
- DIOM01 can also be used as a single channel counter module.

Ordering Code

EXAM01 - ECES01 - PTS01

Options		
Encoder evaluation	ECES01 ECAS01 ECBS01 ECMS01	ENDAT encoder SSI/QUADR. encoder BiSS Resolver no encoder module
Temperature evaluation	PTS01 KTS01	Pt sensor K type no temperature module

Mating connectors are included in delivery.

Ordering Code

PIDM01 - PTS01 - PTS01 - PTS01 - KTS01

Options		
Measuring input 1	PTS01 KTS01	Pt sensor K type
Measuring input 2	PTS01 KTS01	Pt sensor K type
Measuring input 3	PTS01 KTS01	Pt sensor K type
Measuring input 4	PTS01 KTS01	Pt sensor K type

Mating connectors are included in delivery.

Ordering Code

DIOM01

Mating connectors are included in delivery.

* see page 2

Industrial

POWER SUPPLY

CPU

INDEX

POWER STAGE

I/O A

TEMP

ENC

Analogue Inputs and Outputs (AIOM01)

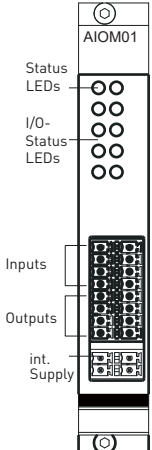

Analogue input and output module

4 analogue inputs and outputs included

Inputs: ± 10 V bipolar, 0...10 V, 0...20 mA
Resolution: 14 Bit

Outputs: Max. output current: 16 mA
Resolution: 16 Bit
Short-circuit proof
Thermal overload protection

Electrically isolated

Ordering Code

Type

AIOM01

Mating connectors are included in delivery.

POWER SUPPLY

CPU

INDEX

POWER STAGE

I/O A

Customised Modules



On demand

Customised modules can be realised on demand.

HMI-Interfaces

Android-based integrated Touch Panel (TPM01)



Integrated human-machine interface

- 800 x 480 px – TFT display
- Integrated in the *phyMOTION*™ housing
- Touch functionality
- As user interface i.e. for parameter selection
- For support, parameterisation and diagnostics

Ordering Code

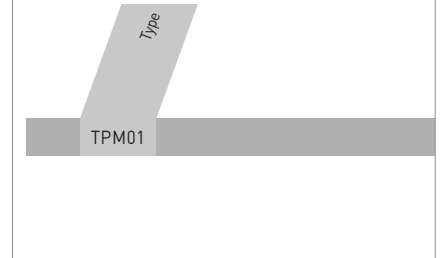

Control via Android-based Tablets (from version V 4.0)



External human-machine interface

- from 480 x 800 px (recommended: 7"-display) – TFT display
- For connection to the POWM01 main power module (Ethernet or WLAN)
- Touch functionality
- As user interface i.e. for parameter selection
- For support, parameterisation and diagnostics

Ordering Code

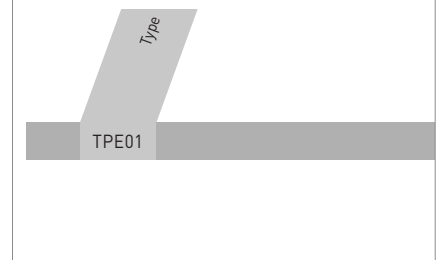

Control with Operator Touch Panel (TPE01)



External human-machine interface

- For connection to the POWM01 main power module (terminal interface)
- 800 x 480 px – TFT display
- Touch functionality
- For configuration, service and diagnostics
- Housing:
 - Rear cover: galvanised steel BTK
 - housing frame: PC UL 94 V0 BTA
 - front frame: aluminium anodised
- up to IP 65/DIN EN 60529

Industrial

Control with Operator Panel BT5 AM



External human-machine interface

- For connection to the POWM01 main power module (terminal interface)
- For support, parameterisation and diagnostics
- Status display, operating mode
- Parameter reading
- Function keys
- Remote or Local mode

Ordering Code

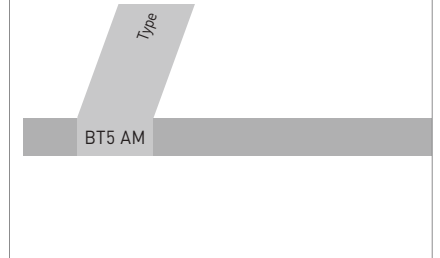

Software

phyLOGIC™ ToolBox

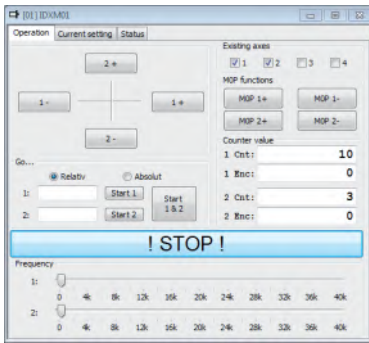

Free of charge development environment

- Operating software and development environment for the phyMOTION™ Phytron controller
- Easy to program: Drawing and converting of 2D contours in phyLOGIC™ commands (Motion Creator)
- Parameterising, programming, editing, debugging
- Support in the commissioning phase i.e. by test functions
- Display of status and graphical presentation of a current XY position
- Archiving of parameter sets and programs

phyLOGIC™ Control



Free of charge App for tablets and mobile phones

- Operating software for tablets connected to the phyMOTION™ Phytron controller
- Direct mode, operating mode, I/O monitor, configuration of the controller
- Status display and parameter reading

LabVIEW®-VI



VIs for phyMOTION™

- Simulation software with a graphical style
- Use the VIs (Virtual Instruments) generated by Phytron and integrate them in your LabVIEW® project. So you can easily control the Phytron controller phyMOTION™ from your usual programming environment.

EPICS Motor Module



Software environment for large-scale experiments

- Software environment to develop and realise distributed control systems for large-scale experiments such as telescopes and accelerators. EPICS provides the SCADA support.
- Download of the driver at: <http://www.aps.anl.gov/bcda/synApps/motor/tar/motorR6-9.tar.gz> to integrate the Phytron controller *phyMOTION™* into the EPICS environment.
- Also in multi-axis operation: positioning, limit switches, encoder evaluation

Equipment

Motor Shield Clamp



Shielding for motor connection

- Easy to go
- Plug-in connection for motor shielding of the following modules of the Phytron controller *phyMOTION™*: INAM-, EXAM-, I1AM01- or I1AM02- module
- On delivery: shielded clamp with cableties and screws
- The motor connectors are included in the package of your *phyMOTION™* controller.

Ordering ID

10015002

Strain Relief for Motor cable



Mountable rail for strain relief of the motor cables

- Dimension: (482.6 x 44.5 x 8) mm
- Material: Aluminium
- 21 cable clamps
- Mountable at the 19"-switching cabinet with two M3 screws

Ordering ID

10019310

Carrying and Assembly Handle



For 19"-Housing

- Shapely and universal
- Grip adjustment by pushbutton by 30°
- Material:
handle profile: extruded aluminium
handle bar, housing adapter:
zinc die cast
- Surface:
handle bar: RAL 9011 graphite black
pushbutton, screw lens:
black plastic
- Carrying capacity: 50 kg

int

Ordering ID

10019311

Industrial

4 Order and Receive the Fully Assembled phyMOTION™

Configuration Example

int

phyMOTION™ with internal supply and housing depth p

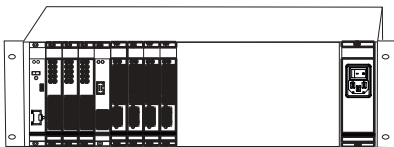

Ordering code example:

	Ordering code	Description
Housing	phyMOTION-21SL-R-p	19" subrack housing, housing depth 360 mm

Modules	Ordering code	Description
Slot 1	MCM03-ETHS01	Main controller with Ethernet interface, internal supply
Slot 2	DIOM01	Digital I/O module
Slot 3	DIOM01	Digital I/O module
Slot 4	DIOM01	Digital I/O module
Slot 5	I4XM01	4 axes indexer module
Slot 6	INAM02-MSX*-ECAS01	MSX* power stage with Quadratic encoder evaluation
Slot 7	INAM02-MSX*-ECES01	MSX* power stage with Endat encoder evaluation
Slot 8	INAM02-MSX*-ECAS01	MSX* power stage with Quadratic encoder evaluation
Slot 9	INAM01-APS01-ECES01-KTS	Internal 5 A power stage with Endat-Enc./Motor temp.-evaluation
Slot 10 -19	-	blank front panels
Slot 20	NETM01-230V-120V-120V-120V	Ext. mains voltage 230 V, 3 x 500 W for 120 V

phyMOTION™ with SLS

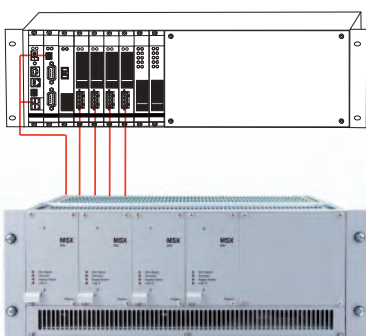

Ordering Code Example:

	Ordering code	Description
Housing	phyMOTION-21SL-R-p	19" subrack housing, housing depth 360 mm

Modules	Ordering code	Description
Slot 1	POWM01	Main supply module
Slot 2	MCM01-RSS485	Main controller with RS 485 interface
Slot 3	I4XM01	4 axes indexer module
Slot 4	EXAM01-ECAS01	Indexer interface for MSX power stage with Quadr.-encoder eval.
Slot 5	EXAM01-ECAS01	Indexer interface for MSX power stage with Quadr.-encoder eval
Slot 6	EXAM01-ECAS01	Indexer interface for MSX power stage with Quadr.-encoder eval
Slot 7	EXAM01-ECES01-KTS	Indexer interface for MSX power stage with Endat-encoder-/ Motor temp. evaluation
Slot 8	DIOM01	Digital I/O module
Slot 9	DIOM01	Digital I/O module

APPLICATION in SCIENCE



Use for Vacuum Chambers



Vacuum chambers are the core of many modern research and production plants.

The *phyMOTION™* offers additional functions for the control of also complex machines from outside the vacuum chamber such as temperature monitoring, encoder and resolver evaluation as well as linear and circular interpolation for high-precision positioning. The heating of the motors is minimised in the application by the high-quality power stage design.

The *phyMOTION™* with integrated power stages close to the vacuum chamber allows a low-noise monitoring of the temperature sensors and a direct motor cable connection.

For large systems make sure that the automation for the vacuum actuators can be seamlessly integrated into the existing PLC world despite the special requirements.

The integrated power stages can be optionally provided with temperature monitoring and encoder evaluation.

The integrated field bus interface allows both the control out of a PLC system SPS-System and the operation via supplied software, LabView interface or touch panel.

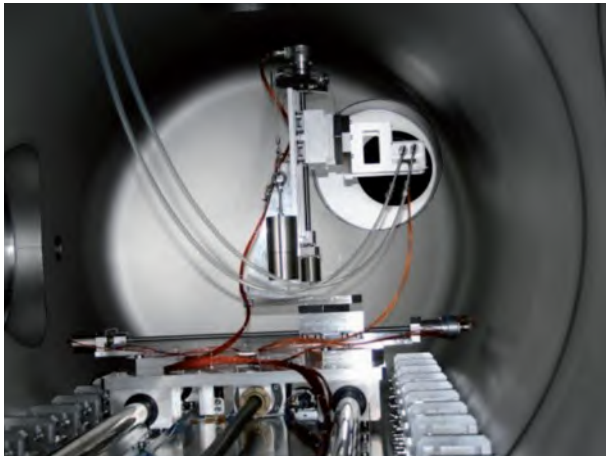

The *phyMOTION™* is also successfully used in the research plant Max Planck Institute for Extraterrestrial Physics, Neuried for aligning optical systems in a vacuum.

The controller is controlled via Ethernet and LabView.

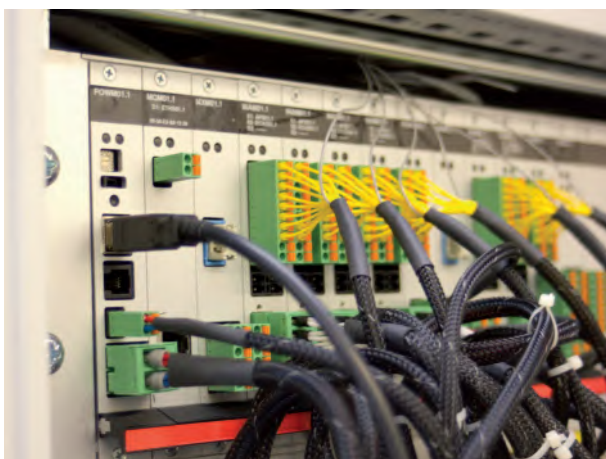

Configuration:

phyMOTION™ with external supply:

MCM01, POWM01, POWM02, 2 x I4XM01, 6 x I1AM01, 2 x DIOM01

APPLICATION in FOOD



XY Alignment for Cutting Baked Wafer Blanks



The *phyMOTION*™ is part of the circular cutting machine for wafers. Here, the baking wafers are cut with a rotating circular blade out of the baked blanks



The radius-dependent, area optimisation XY positioning of the semi-finished goods under the punching knife is controlled by the *phyMOTION*™. The external touch panel allows a comfortable operation.



Configuration:

phyMOTION™ in combination with a plug-in power stage unit SLS with internal power supply: MCM02 with ETHS01, I4XM01, 2x INAM02, 1x DIOM01, 2x MSX152 power stages, external touch operator panel

Configuration Example

19" rack housing with internal supply and integrated touch panel: 4 axes with indexer and I/Os

ext

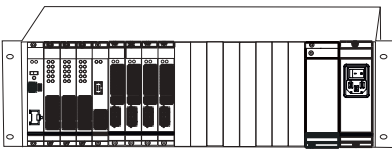

Ordering Code Example:

	Ordering Code	Description
Housing	phyMOTION-21SL-p	19" rack mounting housing with 10 slots, integrated touch panel and depth 360 mm

Module	Ordering Code	Description
TPM01	TPM01	Android-based integrated touch panel
Slot 1	POWM03	Main power supply
Slot 2	MCM03-PBS01	Main controller with ProfiBus interface
Slot 3	DIOM01	Digital I/O module
Slot 4	DIOM01	Digital I/O module
Slot 5	I4XM01	4 axes indexer module
Slot 6	INAM01-APS01-ECAS01	Internal 5 A power stage with Quadratic encoder evaluation
Slot 7	INAM02-MSX ⁺ -ECMS01	1 axis module for integrated MSX ⁺ power stage with resolver
Slot 8	INAM02-MSX ⁺ -ECMS01	1 axis module for integrated MSX ⁺ power stage with resolver
Slot 9	INAM02-MSX ⁺ -ECMS01	1 axis module for integrated MSX ⁺ power stage with resolver
Slot 10	NETM01	230 V [115 V] supply with grounding connection if motor voltage >70 V

p

Industrial

Configuration Example

10-Slot housing for rack mounting: 4 axes with indexer and I/Os

ext

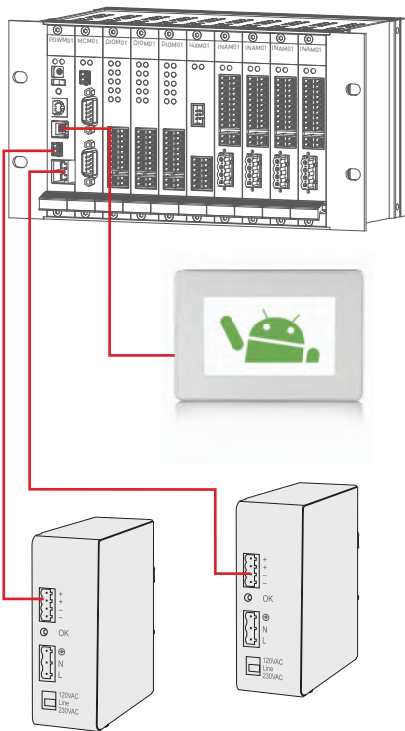

Ordering Code Example:

	Ordering Code	Description
Housing	phyMOTION-10SL-R-s	Rack mounting housing with 10 slots and depth 120 mm
Module	Ordering Code	Description
Slot 1	POWM01	Main power supply
Slot 2	MCM01-RSS01	Main controller with RS 485 interface
Slot 3	DIOM01	Digital I/O module
Slot 4	DIOM01	Digital I/O module
Slot 5	DIOM01	Digital I/O module
Slot 6	I4XM01	4 axes indexer module
Slot 7	INAM01-APS01-ECAS01	Internal 5 A power stage with Quadratic encoder evaluation
Slot 8	INAM01-APS01-ECES01	Internal 5 A power stage with ENDAT encoder evaluation
Slot 9	INAM01-APS01-ECAS01-PTS	Internal 5 A power stage with Quadratic encoder- and motor temperature evaluation with PT sensor
Slot 10	INAM01-APS01-ECES01-KTS	Internal 5 A power stage with ENDAT encoder- and motor temperature evaluation with K types
Power supply	SPH240-2410-W	External power supply unit with 240 W, 24 V _{DC} output voltage and 10 A for rear wall
Power supply	SPH240-4805-W	External power supply unit with 240 W, 48 V _{DC} output voltage and 5 A for rear wall
TPE	TPE	External Operator Touch Panel

5

All illustrations, descriptions and technical specifications are subject to modifications, no responsibility is accepted for the accuracy of this information.

Any questions? Please contact us.

Morskate Aandrijvingen BV

Oosterveldsingel 47A
7558 PJ Hengelo (Ov)
The Netherlands

NL
T +31 (0)74 - 760 11 11
info@morskateaandrijvingen.nl
www.morskateaandrijvingen.nl

DE
T +49 692 - 222 34 95
info@morskateantriebstechnik.de
www.morskateantriebstechnik.de

EN
T +31 (0)74 - 760 11 11
info@morskatedrivetechnology.com
www.morskatedrivetechnology.com

Morskate®



Any questions? Please contact us.

Morskate Aandrijvingen BV

Oosterveldsingel 47A
7558 PJ Hengelo (Ov)
The Netherlands

NL

T +31 (0)74 - 760 11 11
info@morskateaandrijvingen.nl
www.morskateaandrijvingen.nl

DE

T +49 692 - 222 34 95
info@morskateantriebstechnik.de
www.morskateantriebstechnik.de

EN

T +31 (0)74 - 760 11 11
info@morskatedrivetechnology.com
www.morskatedrivetechnology.com