

## Sprockets for uni 810/812/815 and uni Magnet type

no. of teeth	pitch diameter		bore						uni reference no.		
			min.		max. PA		max. cast iron		SS304	cast iron	polyamide
	mm	in.	mm	in.	mm	in.	mm	in.			
13	82.0	3.23	20.0	0.79	40.0	1.57	50.0	1.97	-	123281513CI	-
19	117.3	4.62	20.0	0.79	40.0	1.57	50.0	1.97	-	123281519CI	123381519N
21	129.2	5.09	20.0	0.79	40.0	1.57	50.0	1.97	123181521SS	123281521CI	123381521N
23	141.2	5.56	20.0	0.79	40.0	1.57	50.0	1.97	-	123281523CI	123381523N
25	153.2	6.03	20.0	0.79	40.0	1.57	50.0	1.97	-	123281525CI	123381525N
27	165.2	6.50	20.0	0.79	40.0	1.57	57.2	2.25	-	123281527CI	123381527N
29	177.2	6.98	20.0	0.79	40.0	1.57	57.2	2.25	-	123281529CI	123381529N
31	189.3	7.45	20.0	0.79	40.0	1.57	57.2	2.25	-	123281531CI	123381531N



Width of sprockets:  
42.3 mm (1.67 in.)

Bore and keyway upon request.



See page 119



Materials

See page 15



See page 120



See page 116

no. of teeth	minimum B-dimension		wearstrip distance A	
	mm	in.	mm	in.
13	48.0	1.89	39.5	1.56
19	65.0	2.56	61.9	2.44
21	71.0	2.80	67.9	2.67
23	77.0	3.03	73.9	2.91
25	83.0	3.27	79.9	3.15
27	89.0	3.50	85.9	3.38
29	95.0	3.74	91.9	3.62
31	101.0	3.97	97.9	3.85

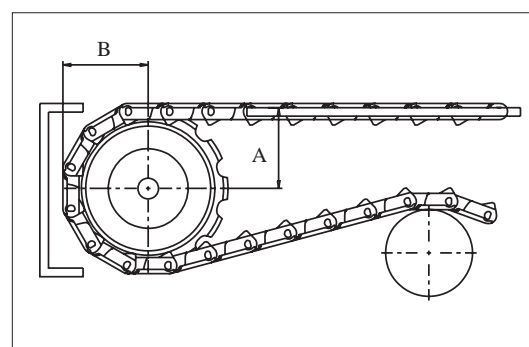

## Sprockets for uni 800/802/805, uni 821, uni 821-PRR4 and uni 821-PRR

no. of teeth	pitch diameter		bore						uni reference no.	
			min.		max. PA		max. cast iron		cast iron	polyamide
	mm	in.	mm	in.	mm	in.	mm	in.		
19	117.3	4.62	20.0	0.79	80.0	3.15	50.0	1.97	-	323382119NP
21	129.2	5.09	20.0	0.79	90.0	3.54	50.0	1.97	323282121CI	323382121NP
23	141.2	5.56	20.0	0.79	90.0	3.54	50.0	1.97	323282123CI	323382123NP
25	153.2	6.03	20.0	0.79	90.0	3.54	50.0	1.97	323282125CI	323382125NP
27	165.2	6.50	20.0	0.79	100.0	3.94	50.0	1.97	323282127CI	323382127NP
29	177.2	6.98	20.0	0.79	100.0	3.94	50.0	1.97	323282129CI	323382129NP
31	189.3	7.45	20.0	0.79	100.0	3.94	50.0	1.97	323282131CI	323382131NP



Width of sprockets:  
79.4 mm (3.13 in.)

Bore and keyway upon request.



See page 119



Materials

See page 15



See page 120



See page 116

no. of teeth	minimum B-dimension		wearstrip distance A	
	mm	in.	mm	in.
19	65.0	2.56	61.9	2.44
21	71.0	2.80	67.9	2.67
23	77.0	3.03	73.9	2.91
25	83.0	3.27	79.9	3.15
27	89.0	3.50	85.9	3.38
29	95.0	3.74	91.9	3.62
31	101.0	3.97	97.9	3.85

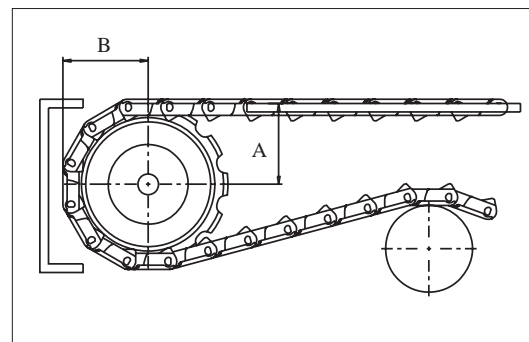

Any questions? Please contact us.

## Sprockets for uni 881/881 TAB and uni 8811/8811 TAB

no. of teeth	pitch diameter		hub diameter		bore						uni reference no.	
	mm	in.	mm	in.	min.		max. PA		max. cast iron		cast iron	polyamide
					mm	in.	mm	in.	mm	in.		
19	117.3	4.62	85.0	3.35	20.0	0.79	50.0	1.97	50.0	1.97	133288119CI	133388119N
21	129.2	5.09	100.0	3.94	20.0	0.79	50.0	1.97	50.0	1.97	133288121CI	133388121N
23	141.2	5.56	110.0	4.33	20.0	0.79	50.0	1.97	50.0	1.97	133288123CI	133388123N
25	153.2	6.03	120.0	4.72	20.0	0.79	50.0	1.97	50.0	1.97	133288125CI	133388125N
27	165.2	6.50	135.0	5.31	20.0	0.79	57.2	2.25	57.2	2.25	133288127CI	133388127N
29	177.2	6.98	150.0	5.91	20.0	0.79	57.2	2.25	57.2	2.25	133288129CI	133388129N
31	189.3	7.45	160.0	6.30	20.0	0.79	57.2	2.25	57.2	2.25	133288131CI	133388131N



**Width of sprockets:**  
42.3 mm (1.67 in.)  
**Tooth width:**  
31.8 mm (1.25 in.)

Bore and keyway upon request.



See page 119



Materials

See page 15



See page 120



See page 117

no. of teeth	minimum B-dimension		wearstrip distance A	
	mm	in.	mm	in.
19	65.0	2.56	61.9	2.44
21	71.0	2.80	67.9	2.67
23	77.0	3.03	73.9	2.91
25	83.0	3.27	79.9	3.15
27	89.0	3.50	85.9	3.38
29	95.0	3.74	91.9	3.62
31	101.0	3.97	97.9	3.85

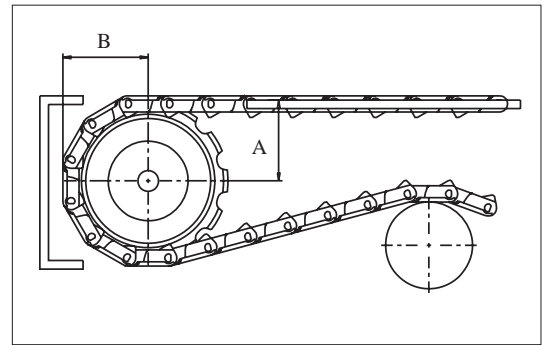

## Sprockets for uni 881 Super Flex and 8811 Super Flex

no. of teeth	pitch diameter		hub diameter		bore				uni reference no.
	mm	in.	mm	in.	min.		max. PA		polyamide
					mm	in.	mm	in.	
19	117.3	4.62	65.0	2.56	20.0	0.79	40.0	1.57	1333SFL19N
21	129.2	5.09	80.0	3.15	20.0	0.79	50.0	1.97	1333SFL21N
23	141.2	5.56	90.0	3.54	20.0	0.79	50.0	1.97	1333SFL23N
25	153.2	6.03	100.0	3.94	20.0	0.79	50.0	1.97	-
27	165.2	6.50	115.0	4.53	20.0	0.79	57.2	2.25	1333SFL27N
29	177.2	6.98	130.0	5.12	20.0	0.79	57.2	2.25	1333SFL29N
31	189.3	7.45	140.0	5.51	20.0	0.79	57.2	2.25	1333SFL31N



**Width of sprockets:**  
42.3 mm (1.67 in.)  
**Tooth width:**  
22.0 mm (0.87 in.)

Bore and keyway upon request.



See page 119



Materials

See page 15



See page 120

no. of teeth	minimum B-dimension		wearstrip distance A	
	mm	in.	mm	in.
19	65.0	2.56	61.9	2.44
21	71.0	2.80	67.9	2.67
23	77.0	3.03	73.9	2.91
25	83.0	3.27	79.9	3.15
27	89.0	3.50	85.9	3.38
29	95.0	3.74	91.9	3.62
31	101.0	3.97	97.9	3.85

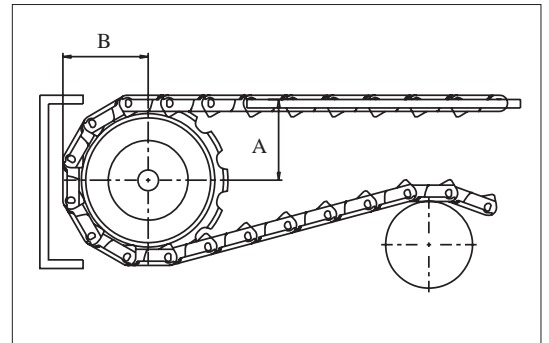

## Sprockets for uni 820 and uni 831

no. of teeth	pitch diameter		bore						uni reference no.	
			min.		max. PA		max. cast iron			
	mm	in.	mm	in.	mm	in.	mm	in.	cast iron	polyamide
19	117.3	4.62	20.0	0.79	40.0	1.57	50.0	1.97	303282019CI	303382019N
21	129.2	5.09	20.0	0.79	40.0	1.57	50.0	1.97	303282021CI	303382021N
23	141.2	5.56	20.0	0.79	40.0	1.57	50.0	1.97	303282023CI	303382023N
25	153.2	6.03	20.0	0.79	40.0	1.57	50.0	1.97	303282025CI	303382025N
27	165.2	6.50	20.0	0.79	100.0	3.94	57.2	2.25	303282027CI	303382027N
29	177.2	6.98	20.0	0.79	100.0	3.94	57.2	2.25	303282029CI	303382029N
31	189.3	7.45	20.0	0.79	100.0	3.94	57.2	2.25	303282031CI	303382031N



Width of sprockets:  
42.3 mm (1.67 in.)

Bore and keyway upon request.



See page 119



See page 15



See page 120

no. of teeth	minimum B-dimension		uni 820 wearstrip distance A		uni 831 wearstrip distance A	
	mm	in.	mm	in.	mm	in.
19	65.9	2.59	61.8	2.43	60.8	2.39
21	71.8	2.83	67.7	2.67	66.7	2.63
23	77.8	3.06	73.7	2.90	72.7	2.86
25	83.8	3.30	79.7	3.14	78.7	3.10
27	89.8	3.54	85.7	3.37	84.7	3.33
29	95.8	3.77	91.7	3.61	90.7	3.57
31	101.9	4.01	97.8	3.85	96.8	3.81

## Sprockets for uni 440 TAB

no. of teeth	pitch diameter		bore				uni reference no.
			min.		max.		
	mm	in.	mm	in.	mm	in.	polyamide
9	55.7	2.19	10.0	0.39	25.0	0.98	723344009N
12	73.6	2.90	10.0	0.39	35.0	1.38	723344012N
20	121.8	4.80	10.0	0.39	70.0	2.76	723344020N



Width of sprockets:  
25.0 mm (0.98 in.)  
Tooth width:  
15.8 mm (0.62 in.)

Bore and keyway upon request.



See page 15



See page 120

no. of teeth	minimum B-dimension		wearstrip distance A	
	mm	in.	mm	in.
9	35.9	1.41	31.4	1.23
12	44.9	1.77	40.3	1.59
20	69.3	2.73	64.4	2.54

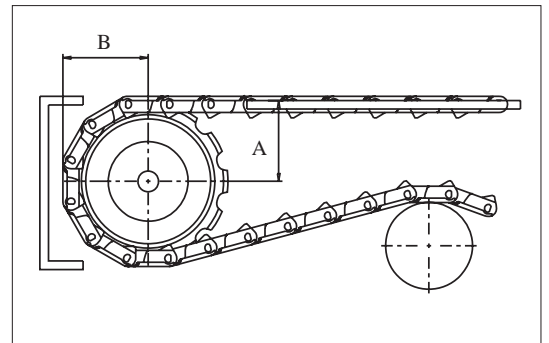

**Sprockets for uni 879/879 TAB/879 TAB-R, uni 879 Super Flex, uni 880/880 TAB/880 TAB-R, uni 880 TAB-RT, uni 880 Super Flex, uni 879 TAB Safety, uni 879 TAB Safety Finger, uni 880 Rib, uni 880 Rib Flex, uni 879 TAB-R-G4,**

no. of teeth	pitch diameter		hub diameter		bore						uni reference no.	
	mm	in.	mm	in.	min.		max. PA		max. cast iron		cast iron	polyamide
					mm	in.	mm	in.	mm	in.		
9	111.4	4.39	63.0	2.48	20.0	0.79	45.0	1.77	44.5	1.75	343288009CI	343388009N
10	123.3	4.85	63.0	2.48	20.0	0.79	45.0	1.77	44.5	1.75	343288010CI	343388010N
11	135.2	5.32	73.5	2.89	20.0	0.79	45.0	1.77	44.5	1.75	343288011CI	343388011N
12	147.2	5.80	73.5	2.89	20.0	0.79	50.0	1.97	44.5	1.75	343288012CI	343388012N
15	183.3	7.22	73.5	2.89	20.0	0.79	50.0	1.97	44.5	1.75	343288015CI	343388015N



**Width of sprockets:**  
42.3 mm (1.67 in.)  
**Tooth width:**  
15.8 mm (0.62 in.)

Bore and keyway upon request.



See page 119



See page 15



See page 120



See page 117

no. of teeth	minimum B-dimension		wearstrip distance A	
	mm	in.	mm	in.
9	63.2	2.49	59.2	2.33
10	69.2	2.72	65.2	2.57
11	75.1	2.96	71.1	2.80
12	81.1	3.19	77.1	3.04
15	99.2	3.91	95.2	3.75

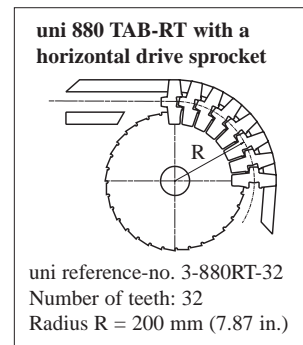

**Sprockets for uni 882, uni 882 TAB, uni 882 SC-TAB, uni 882 Rib Flex, uni 882 PRR-TAB4 and uni 882 PRR-TAB**

no. of teeth	pitch diameter		hub diameter		bore						uni reference no.	
	mm	in.	mm	in.	min.		max. PA		max. cast iron		cast iron	polyamide
					mm	in.	mm	in.	mm	in.		
9	111.4	4.39	63.0	2.48	20.0	0.79	45.0	1.77	44.5	1.75	393288209CI	393388209N
10	123.3	4.85	63.0	2.48	20.0	0.79	45.0	1.77	44.5	1.75	393288210CI	393388210N
11	135.2	5.32	73.5	2.89	20.0	0.79	45.0	1.97	44.5	1.75	393288211CI	393388211N
12	147.2	5.80	73.5	2.89	20.0	0.79	50.0	1.97	44.5	1.75	393288212CI	393388212N
15	183.3	7.22	120.0	4.72	20.0	0.79	50.0	1.97	44.5	1.75	393288215CI	393388215NBB



**Width of sprockets:**  
42.3 mm (1.67 in.)  
**Tooth width:**  
22.2 mm (0.87 in.)

BB = Big Boss (Hub).

Bore and keyway upon request.



See page 119



See page 15



See page 120



See page 117

no. of teeth	minimum B-dimension		wearstrip distance A	
	mm	in.	mm	in.
9	65.4	2.57	60.2	2.37
10	71.4	2.81	66.2	2.43
11	77.3	3.04	72.1	2.84
12	83.3	3.28	78.1	3.07
15	101.4	3.99	96.2	3.79

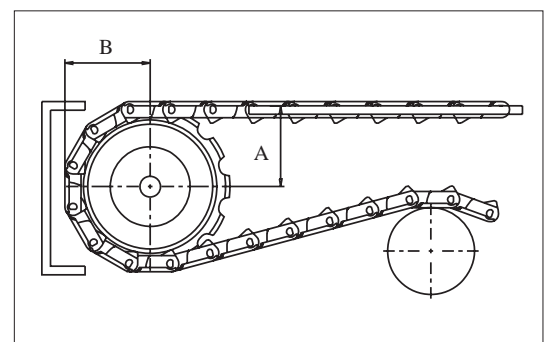

### Terminal for uni 982-SC

no. of teeth	pitch diameter		hub diameter		bore				uni reference no.
	mm	in.	mm	in.	min.		max.		
					mm	in.	mm	in.	polyamide
10	161.8	6.37	64.0	2.52	19.1	0.75	40.0	1.57	4533982SC10N

**Materials** See page 15

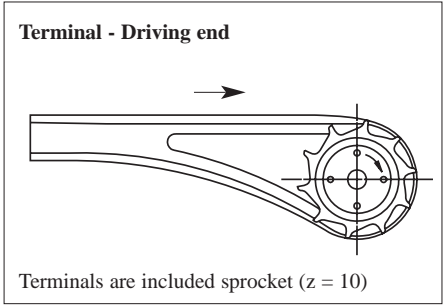
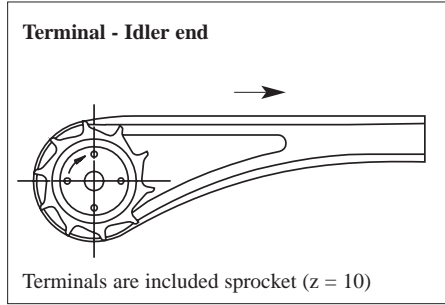

### Sprockets for uni 821-RO

no. of teeth	pitch diameter		bore				uni reference no.
	mm	in.	min.		max.		
			mm	in.	mm	in.	polyamide
21	129.2	5.09	19.1	0.75	80.0	3.15	3233821RO21N



Bore and keyway upon request.

**Materials** See page 15

no. of teeth	minimum B-dimension		wearstrip distance A	
	mm	in.	mm	in.
21	71.0	2.80	67.8	2.67

Width of sprockets:  
135.0 mm (5.31 in.)

See page 120

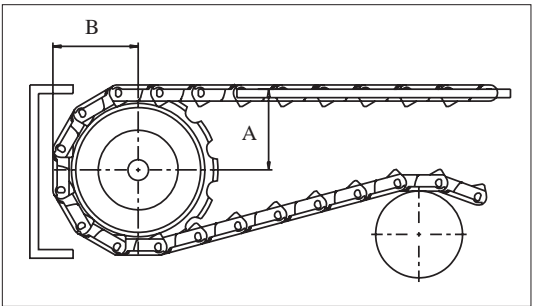

### Sprockets for uni NH78

no. of teeth	pitch diameter		hub diameter		bore				uni reference no.
	mm	in.	mm	in.	min.		max.		
					mm	in.	mm	in.	polyamide
6	132.5	5.21	65.0	2.56	20.0	0.79	40.0	1.57	3533NH7806N
8	173.2	6.82	65.0	2.56	20.0	0.79	40.0	1.57	3533NH7808N
10	214.4	8.44	73.5	2.89	20.0	0.79	50.0	1.97	3533NH7810N



Width of sprockets:  
42.3 mm (1.67 in.)  
Tooth width:  
15.0 mm (0.59 in.)

Bore and keyway upon request.

**Materials** See page 15

no. of teeth	minimum B-dimension		wearstrip distance A	
	mm	in.	mm	in.
6	81.1	3.19	52.0	2.05
8	101.3	3.99	72.3	2.85
10	121.9	4.80	92.9	3.66

See page 120

## Sprockets for uni 3200/3200 TAB

no. of teeth	pitch diameter		hub diameter		bore				uni reference no.		
	mm	in.	mm	in.	min.		max.		polyamide		
					mm	in.	mm	in.			
8	132.8	5.23	65.0	2.56	19.1	0.75	40.0	1.57	<b>3733320008N</b>		
10	164.4	6.61	65.0	2.56	19.1	0.75	40.0	1.57	<b>3733320010N</b>		
			120.0	4.72	19.1	0.75	70.0	2.76	3733320010NBB		
12	196.3	7.73	65.0	2.56	19.1	0.75	40.0	1.57	<b>3733320012N</b>		
			120.0	4.72	19.1	0.75	70.0	2.76	3733320012NBB		
15	244.3	9.62	65.0	2.56	19.1	0.75	40.0	1.57	<b>3733320015N</b>		
			120.0	4.72	19.1	0.75	70.0	2.76	3733320015NBB		



**Width of sprockets:**  
42.3 mm (1.67 in.)  
**Tooth width:**  
25.0 mm (0.98 in.)

BB = Big Boss (Hub).  
Bore and keyway upon request.

 See page 15

 See page 120

no. of teeth	minimum B-dimension		wearstrip distance A	
	mm	in.	mm	in.
8	76.6	3.02	56.3	2.21
10	92.4	3.64	72.1	2.84
12	108.4	4.27	88.0	3.46
15	132.4	5.21	112.0	4.41

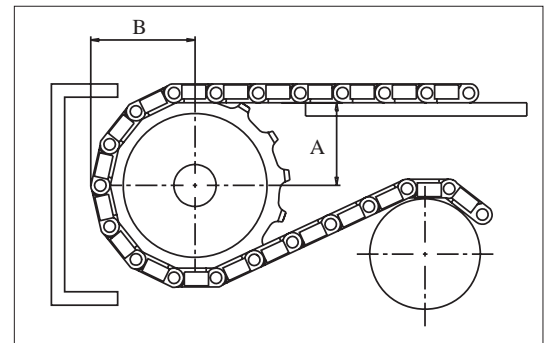

## Sprockets for uni 1700, uni 1701, uni 1701 TAB/TAB-R, uni 1701 TAB-R-ST, uni 1702, uni 1702 M, uni 1702 H, uni 1703, uni 1704, uni 1705, uni 1706 and uni 1707

no. of teeth	pitch diameter		hub diameter		bore						uni reference no.		
	mm	in.	mm	in.	min.		max. PA		max. steel				
					mm	in.	mm	in.	mm	in.	SS304	cast iron	polyamide
8	130.6	5.14	63.0	2.48	20.0	0.79	40.0	1.57	50.0	1.97	3131170008SS	3132170008CI	3133170008N
10	161.8	6.37	63.0	2.48	20.0	0.79	40.0	1.57	50.0	1.97	3131170010SS	3132170010CI	3133170010N
12	193.2	7.61	63.0	2.48	20.0	0.79	40.0	1.57	50.0	1.97	-	3132170012CI	3133170012N
13	208.9	8.23	63.0	2.48	20.0	0.79	40.0	1.57	50.0	1.97	-	3132170013CI	3133170013N



**Width of sprockets:**  
42.3 mm (1.67 in.)  
**Tooth width:**  
11.0 mm (0.43 in.)

Bore and keyway upon request.

 See page 15

 See page 120

no. of teeth	uni 1700, uni 1701, uni 1701 TAB/TAB-R/TAB-R-ST, uni 1702, uni 1702 M, uni 1703, uni 1704 min. B-dimension		uni 1705 and uni 1706 min. B-dimension		uni 1707 min. B-dimension		uni 1700 and uni 1704 wearstrip distance A		uni 1701, uni 1701 TAB/TAB-R/TAB-R-ST, uni 1702, uni 1702 M and uni 1703 wearstrip distance A		uni 1705, uni 1706 and uni 1707 wearstrip distance A	
	mm	in.	mm	in.	mm	in.	mm	in.	mm	in.	mm	in.
8	78.8	3.10	79.0	3.11	82.4	3.24	53.3	2.10	52.6	2.07	47.9	1.89
10	93.9	3.70	93.9	3.70	97.3	3.83	68.9	2.71	68.2	2.69	64.5	2.54
12	109.1	4.30	109.2	4.30	112.4	4.43	84.6	3.33	83.9	3.30	80.8	3.18
13	116.8	4.60	116.8	4.60	120.1	4.73	92.5	3.64	91.8	3.61	89.0	3.50

## Sprockets for uni 2500

no. of teeth	pitch diameter		hub diameter		bore				uni reference no.
	mm	in.	mm	in.	min.		max.		
					mm	in.	mm	in.	
6	127.0	5.00	63.0	2.48	20.0	0.79	40.0	1.57	3533250006N
8	165.9	6.53	73.5	2.89	20.0	0.79	40.0	1.57	3533250008N
15	305.4	12.02	73.5	2.89	20.0	0.79	40.0	1.57	3533250015N



**Width of sprockets:**  
42.3 mm (1.67 in.)  
**Tooth width:**  
11.0 mm (0.43 in.)

Bore and keyway upon request.

**Materials** See page 15

See page 120

no. of teeth	minimum B-dimension		wearstrip distance A	
	mm	in.	mm	in.
6	83.4	3.28	43.5	1.71
8	102.8	4.05	63.0	2.48
15	172.7	6.80	132.7	5.22

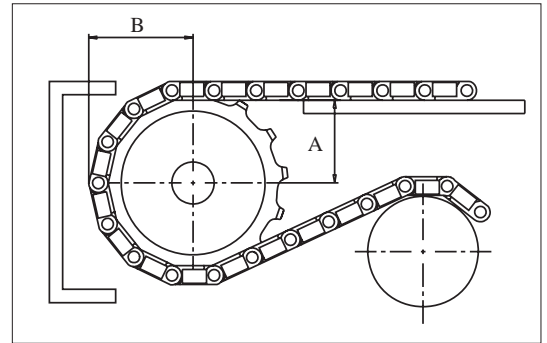

## Sprockets for uni 2600-C, uni 2600-CV, uni 2600-TAB-C, uni 2600-O, uni 2600-OV, uni 2600 TAB-O and uni 2600 TAB-O-M

no. of teeth	pitch diameter		hub diameter		bore				uni reference no.		
	mm	in.	mm	in.	min.		max.		SS304	cast iron	polyamide
					mm	in.	mm	in.			
6	127.0	5.00	63.0	2.48	20.0	0.79	40.0	1.57	-	3632260006CI	3633260006N
8	165.9	6.53	73.5	2.89	20.0	0.79	50.0	1.97	3631260008SS	3632260008CI	3633260008N
10	205.5	8.09	73.5	2.89	20.0	0.79	50.0	1.97	-	3632260010CI	3633260010N
11	225.4	8.87	73.5	2.89	20.0	0.79	50.0	1.97	-	3632260011CI	3633260011N



**Width of sprockets:**  
42.3 mm (1.67 in.)  
**Tooth width:**  
11.0 mm (0.43 in.)

Bore and keyway upon request.

**Materials** See page 15

See page 120

no. of teeth	minimum B-dimension		wearstrip distance A	
	mm	in.	mm	in.
6	78.1	3.07	49.0	1.93
8	97.5	3.84	68.5	2.69
10	117.2	4.61	88.3	3.47
11	127.2	5.01	98.2	3.89

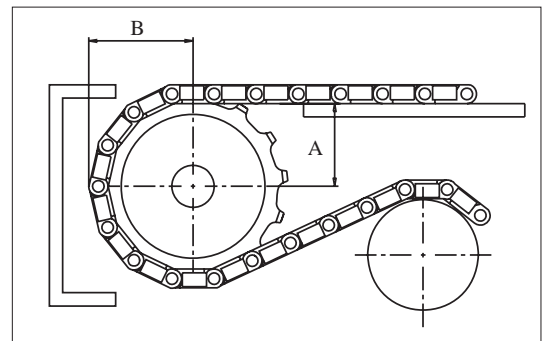

### Sprockets for uni 2700/2700-R, uni 2700 H/2700 H-R and uni 2700 LH

no. of teeth	pitch diameter		hub diameter		bore				uni reference no.	
	mm	in.	mm	in.	min.		max.		cast iron	polyamide
					mm	in.	mm	in.		
8	182.9	7.20	73.5	2.89	20.0	0.79	50.0	1.97	3733270008CI	3733270008N
10	226.5	8.92	73.5	2.89	20.0	0.79	50.0	1.97	-	3733270010N



**Width of sprockets:**  
42.3 mm (1.67 in.)  
**Tooth width:**  
15.0 mm (0.59 in.)

Bore and keyway upon request.



See page 15



See page 120

no. of teeth	minimum B-dimension		wearstrip distance A	
	mm	in.	mm	in.
8	116.9	4.60	65.0	2.56
10	137.8	5.43	86.8	3.42

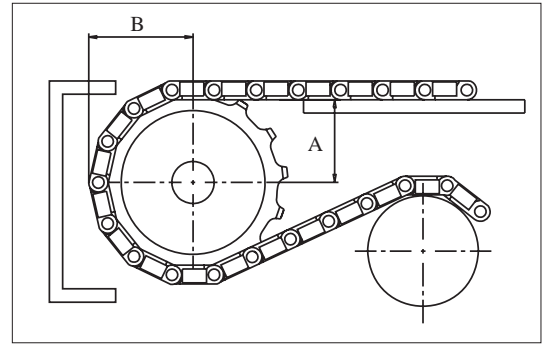

### Sprockets for uni 3000

no. of teeth	pitch diameter		hub diameter		bore				uni reference no.
	mm	in.	mm	in.	min.		max.		polyamide
					mm	in.	mm	in.	
10	259.2	10.20	75.0	2.95	20.0	0.79	50.0	1.97	3733300010N



**Width of sprockets:**  
42.3 mm (1.67 in.)  
**Tooth width:**  
15.0 mm (0.59 in.)

Bore and keyway upon request.



See page 15



See page 120

no. of teeth	minimum B-dimension		wearstrip distance A	
	mm	in.	mm	in.
10	155.6	6.13	106.0	4.17

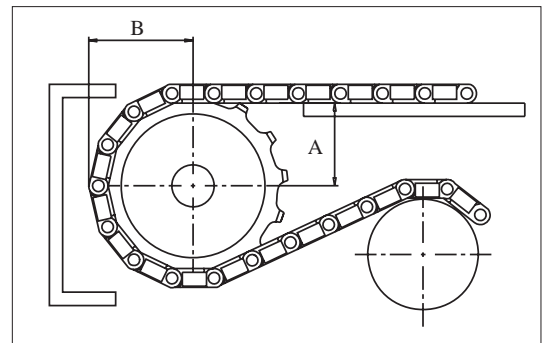

### Sprockets for uni 1400/1400 TAB

no. of teeth	pitch diameter		hub diameter		bore				uni reference no.
	mm	in.	mm	in.	min.		max.		
					mm	in.	mm	in.	
6	165.0	6.50	63.0	2.48	20.0	0.79	40.0	1.57	3333140006N
8	215.6	8.49	73.5	2.89	20.0	0.79	50.0	1.97	3333140008N
10	267.0	10.51	73.5	2.89	20.0	0.79	50.0	1.97	3333140010N



**Width of sprockets:**  
42.3 mm (1.67 in.)  
**Tooth width:**  
15.0 mm (0.59 in.)

Bore and keyway upon request.



See page 15



See page 120

no. of teeth	minimum B-dimension		wearstrip distance A	
	mm	in.	mm	in.
6	101.5	4.00	64.5	2.54
8	126.8	5.00	89.8	3.54
10	132.5	5.22	115.5	4.55

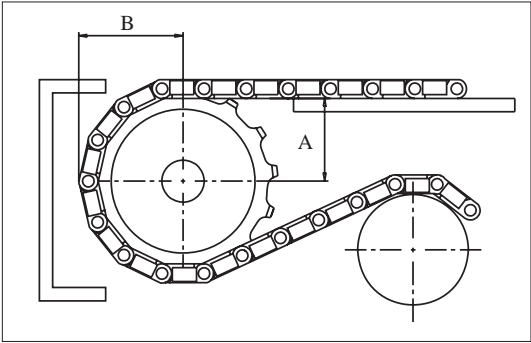

### Sprockets for uni 2800/2800 TAB

no. of teeth	pitch diameter		hub diameter		bore				uni reference no.
	mm	in.	mm	in.	min.		max.		
					mm	in.	mm	in.	
6	165.0	6.50	63.0	2.48	20.0	0.79	40.0	1.57	3833280006N
8	215.6	8.49	73.5	2.89	20.0	0.79	50.0	1.97	3833280008N
10	267.0	10.51	73.5	2.89	20.0	0.79	50.0	1.97	3833280010N



**Width of sprockets:**  
42.3 mm (1.67 in.)  
**Tooth width:**  
15.0 mm (0.59 in.)

Bore and keyway upon request.



See page 15



See page 120

no. of teeth	minimum B-dimension		wearstrip distance A	
	mm	in.	mm	in.
6	101.0	3.98	64.0	2.52
8	126.3	4.97	89.3	3.52
10	152.0	5.98	115.3	4.54

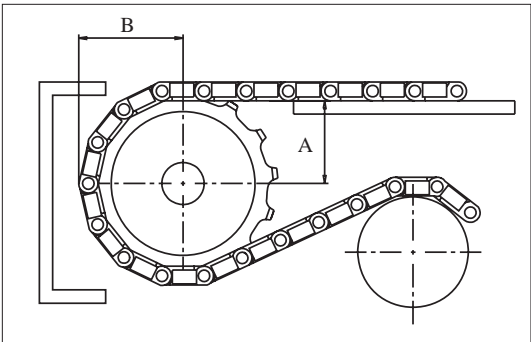

## Two Part Sprockets

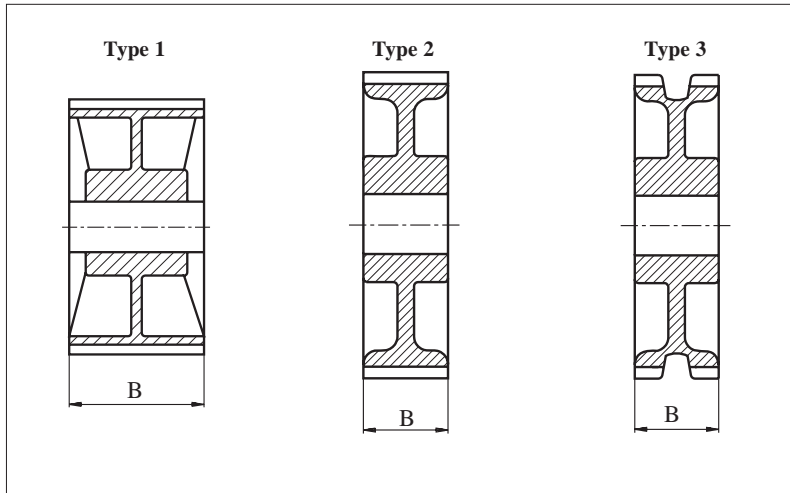

### Type 1: Two part sprockets for uni 800, uni 802, uni 805, uni 821, uni 821-PRR4 and uni 821-PRR

no. of teeth	pitch diameter		hub diameter		tooth width B		bore				uni reference no. polyamide
	mm	in.	mm	in.	mm	in.	min.		max.		
							mm	in.	mm	in.	
25	153.2	6.03	58.0	2.28	80.2	3.16	30.0	1.18	50.8	2.00	323382125NT

Minimum B-dimension and wearstrip distance A: Please see page 107.

### Type 2: Two part sprockets for uni 810, uni 812, uni 815 and uni Magnet type

no. of teeth	pitch diameter		hub diameter		tooth width B		bore				uni reference no. polyamide
	mm	in.	mm	in.	mm	in.	min.		max.		
							mm	in.	mm	in.	
19	117.3	4.62	58.0	2.28	42.3	1.67	20.0	0.78	40.0	1.57	123381519NT
21	129.3	5.09	58.0	2.28	42.3	1.67	20.0	0.78	40.0	1.57	123381521NT
23	141.2	5.56	58.0	2.28	42.3	1.67	20.0	0.78	40.0	1.57	123381523NT
25	153.2	6.03	58.0	2.28	42.3	1.67	20.0	0.78	40.0	1.57	123381525NT

Minimum B-dimension and wearstrip distance A: Please see page 107.

### Type 3: Two part sprockets for uni 820 and uni 831

no. of teeth	pitch diameter		hub diameter		tooth width B		bore				uni reference no. polyamide
	mm	in.	mm	in.	mm	in.	min.		max.		
							mm	in.	mm	in.	
19	117.3	4.62	58.0	2.28	42.3	1.67	20.0	0.78	40.0	1.57	303382019NT
21	129.3	5.09	58.0	2.28	42.3	1.67	20.0	0.78	40.0	1.57	303382021NT
23	141.2	5.56	58.0	2.28	42.3	1.67	20.0	0.78	40.0	1.57	303382023NT
25	153.2	6.03	58.0	2.28	42.3	1.67	20.0	0.78	40.0	1.57	303382025NT

Minimum B-dimension and wearstrip distance A: Please see page 109.

Materials

See page 15

## Two Part Sprockets

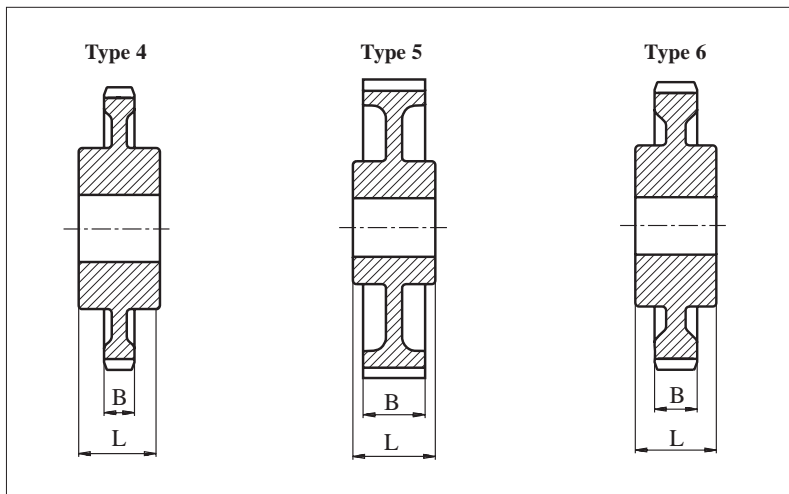

**Type 4:** Two part sprockets for uni 879, uni 879 TAB, uni 879 Super Flex, uni 880, uni 880 TAB, uni 880 TAB-RT, uni 880 Super Flex, uni 879 TAB Safety, uni 879 TAB Safety Finger, uni 880 Rib, uni 880 Rib-Flex and uni 879 TAB-R-G4

no. of teeth	pitch diameter		hub diameter		tooth width L		tooth width B		bore				uni reference no.
	mm	in.	mm	in.	mm	in.	mm	in.	min.		max.		
9	111.4	4.39	52.0	2.05	42.3	1.67	15.8	0.62	20.0	0.78	40.0	1.57	343388009NT
10	123.3	4.85	52.0	2.05	42.3	1.67	15.8	0.62	20.0	0.78	40.0	1.57	343388010NT
11	135.2	5.32	52.0	2.05	42.3	1.67	15.8	0.62	20.0	0.78	40.0	1.57	343388011NT
12	147.2	5.80	52.0	2.05	42.3	1.67	15.8	0.62	20.0	0.78	40.0	1.57	343388012NT

Minimum B-dimension and wearstrip distance A: Please see page 110.

**Type 5:** Two part sprockets for uni 881, uni 881 TAB, uni 8811 and uni 8811 TAB

no. of teeth	pitch diameter		hub diameter		tooth width L		tooth width B		bore				uni reference no.
	mm	in.	mm	in.	mm	in.	mm	in.	min.		max.		
19	117.3	4.62	58.0	2.28	42.3	1.67	31.8	1.25	20.0	0.78	40.0	1.57	133388119NT
21	129.3	5.09	58.0	2.28	42.3	1.67	31.8	1.25	20.0	0.78	40.0	1.57	133388121NT
23	141.2	5.56	58.0	2.28	42.3	1.67	31.8	1.25	20.0	0.78	40.0	1.57	133388123NT
25	153.2	6.03	58.0	2.28	42.3	1.67	31.8	1.25	20.0	0.78	40.0	1.57	133388125NT

Minimum B-dimension and wearstrip distance A: Please see page 108.

**Type 6:** Two part sprockets for uni 882, uni 882 TAB, uni 882 SC-TAB, uni 882 Rib-Flex, uni 882 PRR-TAB4 and uni 882 PRR-TAB

no. of teeth	pitch diameter		hub diameter		tooth width L		tooth width B		bore				uni reference no.
	mm	in.	mm	in.	mm	in.	mm	in.	min.		max.		
10	123.3	4.85	52.0	2.05	42.3	1.67	22.2	0.87	20.0	0.78	40.0	1.57	393388210NT
11	135.2	5.32	58.0	2.28	42.3	1.67	22.2	0.87	20.0	0.78	40.0	1.57	393388211NT
12	147.2	5.80	58.0	2.28	42.3	1.67	22.2	0.87	20.0	0.78	40.0	1.57	393388212NT

Minimum B-dimension and wearstrip distance A: Please see page 110.

Materials

See page 15

## Sprockets for Snap-On Chains

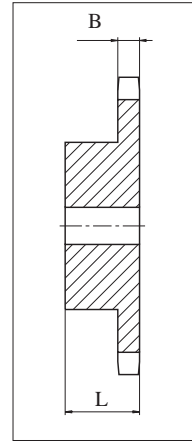

### Sprockets for Snap-On series uni 843, uni SK843 and uni 1843 - 1/2" x 5/16" Form B

no. of teeth	pitch diameter		hub diameter		overall width L		tooth width B		bore		uni reference no.
	mm	in.	mm	in.	mm	in.	mm	in.	mm	in.	
17	69.1	2.72	52.0	2.05	28.0	1.10	7.2	0.28	12.0	0.47	590000462B017
18	73.1	2.88	56.0	2.20	28.0	1.10	7.2	0.28	12.0	0.47	<b>590000462B018</b>
19	77.2	3.04	60.0	2.36	28.0	1.10	7.2	0.28	12.0	0.47	590000462B019
20	81.2	3.20	64.0	2.52	28.0	1.10	7.2	0.28	12.0	0.47	590000462B020
21	85.2	3.35	68.0	2.68	28.0	1.10	7.2	0.28	14.0	0.55	590000462B021
22	89.2	3.51	70.0	2.76	28.0	1.10	7.2	0.28	14.0	0.55	590000462B022
23	93.3	3.67	70.0	2.76	28.0	1.10	7.2	0.28	14.0	0.55	590000462B023
24	97.3	3.83	70.0	2.76	28.0	1.10	7.2	0.28	14.0	0.55	590000462B024
25	101.3	3.99	70.0	2.76	28.0	1.10	7.2	0.28	14.0	0.55	<b>590000462B025</b>

### Sprockets for Snap-On series uni 863/963, uni 863 TAB/963 TAB, uni 1873 and uni 3873 3/4" x 1/2" Form B

no. of teeth	pitch diameter		hub diameter		overall width L		tooth width B		bore		uni reference no.
	mm	in.	mm	in.	mm	in.	mm	in.	mm	in.	
17*	103.7	4.08	80.0	3.15	35.0	1.38	11.7	0.46	16.0	0.63	590000513B017
18*	109.7	4.32	80.0	3.15	35.0	1.38	11.7	0.46	16.0	0.63	590000513B018
19	115.7	4.56	80.0	3.15	35.0	1.38	11.7	0.46	16.0	0.63	<b>590000513B019</b>
20	121.8	4.79	80.0	3.15	35.0	1.38	11.7	0.46	16.0	0.63	<b>590000513B020</b>
21	127.8	5.03	90.0	3.54	40.0	1.57	11.7	0.46	20.0	0.79	590000513B021
22	133.9	5.27	90.0	3.54	40.0	1.57	11.7	0.46	20.0	0.79	590000513B022
23	139.9	5.51	90.0	3.54	40.0	1.57	11.7	0.46	20.0	0.79	590000513B023
24	146.0	5.75	90.0	3.54	40.0	1.57	11.7	0.46	20.0	0.79	590000513B024
25	152.0	5.98	90.0	3.54	40.0	1.57	11.7	0.46	20.0	0.79	<b>590000513B025</b>
26	158.0	6.22	95.0	3.74	40.0	1.57	11.7	0.46	20.0	0.79	590000513B026
27	164.1	6.46	95.0	3.74	40.0	1.57	11.7	0.46	20.0	0.79	590000513B027
28	170.1	6.70	95.0	3.74	40.0	1.57	11.7	0.46	20.0	0.79	590000513B028
29	176.2	6.94	95.0	3.74	40.0	1.57	11.7	0.46	20.0	0.79	590000513B029
30	182.3	7.18	95.0	3.74	40.0	1.57	11.7	0.46	25.0	0.98	590000513B030
32	194.4	7.65	100.0	3.94	40.0	1.57	11.7	0.46	25.0	0.98	590000513B032
34	206.5	8.13	100.0	3.94	40.0	1.57	11.7	0.46	25.0	0.98	590000513B034

\* These sizes are too small for the uni 863TAB/963TAB, uni 1873 and uni 3873 series.

## Idlers

Idlers are available for: uni 810, uni 812, uni 815, uni 881, uni Magnet type, uni 881 Super Flex, uni 8811, uni 8811 Super Flex, uni 820, uni 831, uni 879, uni 879 Super Flex, uni 880 and uni 880 Super Flex.



Corresponding to sprocket with number of teeth	B		overall diameter D		bore d				L		uni reference nr.
					min.		max.				
	mm	in.	mm	in.	mm	in.	mm	in.	mm	in.	
19	44.4	1.75	116.9	5.11	20.0	0.79	38.1	1.50	63.5	2.50	303382019DIN
21	44.4	1.75	129.8	5.11	20.0	0.79	38.1	1.50	63.5	2.50	303382021DIN
23	44.4	1.75	142.2	5.60	20.0	0.79	38.1	1.50	63.5	2.50	303382023DIN
25	44.4	1.75	154.7	6.09	20.0	0.79	38.1	1.50	63.5	2.50	303382025DIN

All idlers are supplied with pilot bore.

Standard material: **POM-D**

Materials See page 14

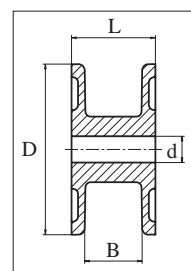

## Guide Rings

The sprockets for the steel chains uni 810/812/815/800/802/805 and uni Magnet type can be supplied with guide rings if the drive sprockets are to guide the chain.

No. of teeth	overall diameter D		clamping diameter radius R <sub>c</sub>		thickness of ring		shape of ring	uni reference no.
	mm	in.	mm	in.	mm	in.		
17	104.4	4.11	39.7	1.56	1.5	0.06	A	122GR1718S
18	104.4	4.11	39.7	1.56	1.5	0.06	A	
19	116.3	4.58	45.5	1.79	3.0	0.12	A	122GR1920S
20	116.3	4.58	45.5	1.79	3.0	0.12	A	
21	129.3	5.10	53.0	2.09	3.0	0.12	A	122GR2122S
22	129.3	5.10	53.0	2.09	3.0	0.12	A	
23	141.2	5.56	57.0	2.24	3.0	0.12	A	122GR2324S
24	141.2	5.56	57.0	2.24	3.0	0.12	A	
25	153.2	6.03	63.6	2.50	3.0	0.12	A	122GR2526S
26	153.2	6.03	63.6	2.50	3.0	0.12	A	
27	165.2	6.50	70.0	2.76	3.0	0.12	A	122GR2728S
28	165.2	6.50	70.0	2.76	3.0	0.12	A	
29	178.3	7.02	76.0	2.99	3.0	0.12	B	122GR2930S
30	178.3	7.02	76.0	2.99	3.0	0.12	B	
31	190.5	7.50	82.0	3.23	3.0	0.12	B	122GR3132S
32	190.5	7.50	82.0	3.23	3.0	0.12	B	

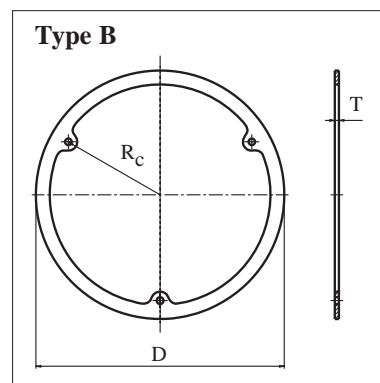
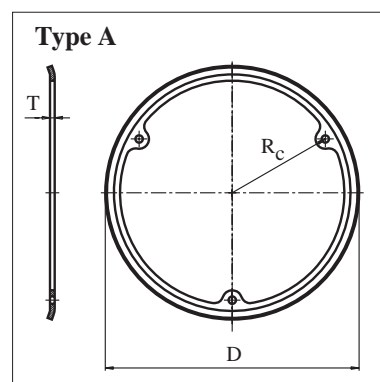

All guide rings are supplied with 3 clamping holes  $\phi$  4.8 mm (0.19 in.).

Standard material: **DIN 1.0120**